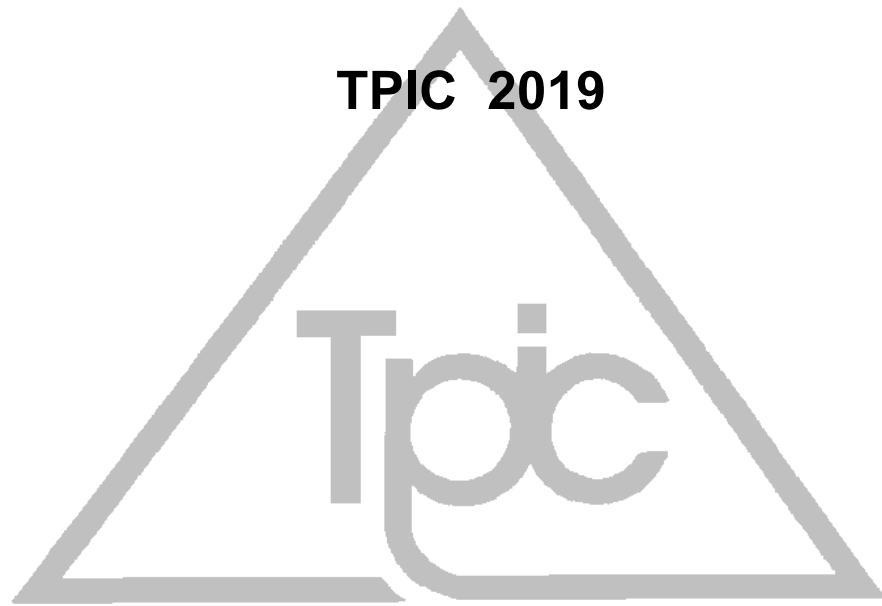


TRUSS DESIGN PROCEDURES AND SPECIFICATIONS  
FOR LIGHT METAL PLATE CONNECTED WOOD TRUSSES

**TPIC 2019**



## **TPIC 2019 Updates**

All reprints are issued to incorporate revisions into the original 2019 design procedures. The replacement pages incorporated into the document are identified by date. Revisions made in the replacement pages are marked by the symbol delta ( $\Delta$ ) in the margin.

**TPIC 2019**  
**Truss Design Procedures and Specifications**  
**for Light Metal Plate Connected Wood Trusses**

©Truss Plate Institute of Canada  
Published June 2019

## Truss Plate Institute of Canada

### Members:

Alpine Systems Corporation  
120 Travail Rd.  
Markham, ON L3S 3J1

London Roof Truss Inc.  
1941 Gore Rd.  
London, ON N5W 6B9

MiTek Canada, Inc.  
100 Industrial Rd.  
Bradford, ON L3Z 3G7

Simpson Strong-Tie Canada, Ltd.  
11476 Kingston St.  
Maple Ridge, BC V2X 0Y5

### Affiliate Members:

AWTFA  
989 Route 605  
Maple Ridge, NB E6E 1W7

OSWA  
5 Glenaden Avenue East  
Toronto, ON M8Y 2L2

WWTA-AB  
212 3916-64<sup>th</sup> Ave. SE  
Calgary, AB T2C 2B4

WWTA-BC  
3187 Caulfield Ridge  
Coquitlam, BC V3E 3P7

WWTA-MB/SK  
P.O. Box 22  
Anola, MB R0E 0A0

### Associate Members:

Cecobois  
1175 Lavigerie Ave, Suite 200  
Quebec, QC G1V 4P1

Modulus Engineering  
22 Mailey Lane  
Barrie, ON L4N 0P3

EWP Design Inc.  
7630 Airport Rd.  
Mississauga, ON L4T 4G6

Etruss Engineering  
2901 Bayview Ave.  
P.O. Box 91039  
Toronto, ON M2K 2Y6

AIMENG Canada Inc.  
81 Grandview Rd.  
Ottawa, ON K2H 8B7

### DISCLAIMER

These recommendations are for the design of metal plate connected wood trusses that originate from the collective experience of leading technical personnel in the metal plate connected wood truss industry, but must, due to the nature of the responsibilities involved, be presented only as a guide for the use of a qualified engineer or designer. By publishing this booklet, the Truss Plate Institute of Canada and its member companies do not warrant the recommendations information contained herein as proper under all conditions and expressly disclaim any responsibility for damages arising from the use, application, or reliance on the recommendations and information contained herein. This standard does not preclude the use of materials, assemblies, structures or designs not meeting the criteria herein, when they demonstrate equivalent performance for the intended use to those specified in this standard.

## Foreward

The purpose of this manual is to present data for design to those familiar with engineering procedures. It does not include information found in standard engineering textbooks which include derivation of formulas. It is not intended that these specifications illustrate all truss configurations or details thereof.

This specification covers materials, both lumber and steel, design procedures for members and joints, including minimum snow loads and minimum dead loads, and evaluation of connector plates.

This specification incorporates the most recent code changes, lumber and design standards and the latest generally accepted engineering procedures and methods. All previous editions of this specification are obsolete.

These specifications do not cover design for the complete structural system of a building. Suitable provisions must be made for adequate supports, cross bracing, wind loading, seismic loading, or other horizontal loading by those responsible for over-all building design.

The design methods contained within this specification are based on sound engineering judgement with specific reference to the Canadian Standards Association (CSA O86-19) and the National Building Code of Canada (NBC 2020). A continuous program of research work is being carried out at various universities and testing laboratories to supplement and enhance this specification.

The purpose of the Truss Plate Institute of Canada is: to serve the needs of manufacturers of truss plates and wood trusses by representation on various committees of recognized organizations dealing with building codes and standards; to establish and promulgate standards for the design, manufacture and quality control of truss plates as may be required; to do all other things to foster and develop truss plate manufacturing and wood truss fabrication industries, consistent with law, and in the mutual interest of members of the organization.

## History of TPIC

**Year 1971** National Building Code of Canada (1970) introduced new classifications and dimensions for lumber construction.

**June 1971** Several major Canadian truss plate manufacturers convened for the purpose of creating the Truss Plate Institute of Canada.

**May 1972** TPIC was incorporated under Canadian law and its constitution and by-laws adopted.

**July 1973** Uniform testing procedures for metal truss plates were developed.

**April 1974** CMHC and TPIC agreed on maximum span tables for publication in N.B.C.C.

**Oct 1976** TPIC Testing procedures for truss plates were adopted as CSA Standard S347.

**May 1977** CMHC recognized TPIC Design Procedures.

**Jan 1981** 3rd Edition of TPIC Design Procedure for Roof and Floor Trusses published.

**Jan 1988** 4th Edition of TPIC Design Procedure for Roof and Floor Trusses published.

**1988 - 1995A** number of addendums, revisions and additional design procedures were added to TPIC 1988 to keep the industry abreast of the latest technical information.

**Nov 1995** The publication, printing and distribution of the National Building Code of Canada introduces Reliability Based design procedures (Limit States design procedures). With Working Stress design procedures to be eliminated, truss testing at Forintek in Vancouver took place through 1993-1995.

**Fall 1997** TPIC 1996 is published introducing truss design procedures and specifications for light metal plate connected wood trusses for Limit States Design.

**Fall 2005** The publication, printing and distribution of the National Building Code of Canada brings about changes in loading Considerations

**June 2007** TPIC 2007 is published updating the document to incorporate changes brought about by NBCC 2005 and considerations for OBC 2006.

**2007 - 2011** A number of addendums, revisions and additional design procedures were added to TPIC 2007 to keep the industry abreast of the latest technical information.

**June 2011** TPIC 2011 is published updating the document to incorporate the various addendums and revisions.

**June 2014** The first major re-formatting of the TPIC design manual is undertaken and TPIC 2014 is published, incorporating the changes to CSA O86-14, for inclusion into NBC 2015. Additional TC bearing details were added based on testing funded by the wood truss industry.

**June 2019** TPIC 2019 is published with new provisions to accommodate the use of structural composite lumber. Updated moment splicing procedures were added to better align with ANSI/TPI1 and mandatory quality control requirements for fabricators were initiated.

## Table of Contents

DISCLAIMER .....	4
Foreward .....	5
History of TPIC .....	5
Design Responsibilities .....	15
1. Scope .....	16
1.1 General .....	16
1.2 Design method .....	16
1.3 Terminology .....	16
2. Reference publications .....	16
3. Definitions, symbols, abbreviations and units .....	17
3.1 Definitions .....	17
3.2 Symbols .....	20
3.3 Abbreviations .....	23
3.4 Units .....	23
4. Materials .....	23
4.1 Lumber sizes and grades .....	23
4.2 Steel .....	23
4.2.1 General .....	23
4.2.2 Corrosion resistant coatings .....	24
4.2.3 Product evaluation reports .....	24
5. General design .....	24
5.1 Specified loads, load effects and load combinations .....	24
5.1.1 Loads applied to buildings .....	24
5.1.2 Loads applied to other structures .....	24
5.1.3 Specified loads .....	24
5.1.3.1 Loads to be considered .....	24
5.1.3.2 Importance category .....	25
5.1.3.3 Importance factors .....	25
5.1.4 Load combinations .....	26
5.1.4.1 Load combinations for ultimate limit states .....	26
5.1.4.2 Load combinations for serviceability limit states .....	26
5.2 Specified snow, live and wind loads .....	27
5.2.1 Roof trusses .....	27
5.2.1.1 Part 9 of NBC 2020 .....	27

5.2.1.2 Part 4 of NBC 2020 .....	27
5.2.1.3 National Farm Building Code of Canada 1995 - Low human occupancy .....	28
5.2.2 Floor trusses .....	28
5.2.2.1 Part 9 of NBC 2020 .....	28
5.2.2.2 Part 4 of NBC 2020 .....	28
5.2.2.3 Vibration .....	28
5.3 Specified dead loads .....	28
5.3.1 Roof dead loads .....	28
5.3.2 Floor dead loads .....	29
6. Member design procedures .....	29
6.1 Method of analysis .....	29
6.1.1 Truss analogue .....	29
6.1.2 Truss model .....	29
6.1.3 Support model .....	30
6.1.4 Member forces and moments .....	30
6.2 Ultimate limit states .....	30
6.3 Serviceability limit states .....	30
6.4 Specified strengths .....	30
6.4.1 Visually stress-graded lumber .....	30
6.4.2 Machine stress-rated and machine evaluated lumber .....	30
6.4.3 Structural composite lumber .....	30
6.4.4 Conditions and factors affecting resistance .....	31
6.4.4.1 General .....	31
6.4.4.2 Load duration factor, $K_D$ .....	31
6.4.4.2.1 General .....	31
6.4.4.2.2 Long term load duration factor .....	31
6.4.4.2.3 Structural composite lumber .....	32
6.4.4.3 Service condition factor, $K_s$ .....	32
6.4.4.3.1 Sawn lumber .....	32
6.4.4.3.2 Structural composite lumber .....	32
6.4.4.4 Preservative and fire-retardant treatment factor, $K_T$ .....	32
6.4.4.4.1 Preservative-treated lumber .....	32
6.4.4.4.2 Fire retardant or other strength reducing chemicals .....	32
6.4.4.4.3 Structural composite lumber .....	33
6.4.4.5 System factor, $K_H$ .....	33
6.4.4.6 Size factor, $K_z$ .....	33
6.4.4.6.1 Visually stress-graded lumber .....	33
6.4.4.6.2 Light framing grades .....	33



6.4.4.6.3 Machine stress-rated and machine evaluated lumber ..... 33

6.4.4.6.4 Structural composite lumber ..... 33

6.4.4.7 Flat roof factor,  $K_F$  ..... 34

6.5 Strength and resistance ..... 34

6.5.1 Bending moment resistance ..... 34

6.5.1.1 Factored bending moment resistance..... 34

6.5.1.2 Lateral stability factor,  $K_L$  ..... 35

6.5.2 Shear resistance ..... 35

6.5.3 Compressive resistance parallel to grain ..... 35

6.5.3.1 Effective length..... 35

6.5.3.2 Simple compression members - constant rectangular cross-section ..... 36

6.5.3.3 Factored compressive resistance parallel to grain ..... 36

6.5.3.4 Slenderness factor,  $K_C$  ..... 36

6.5.4 Compressive resistance perpendicular to grain..... 36

6.5.4.1 General ..... 36

6.5.4.2 Effect of all applied loads ..... 37

6.5.4.3 Effects of loads applied near a support ..... 37

6.5.4.4 Unequal bearing areas on opposite surfaces of a member ..... 37

6.5.4.5 Size factor for bearing,  $K_{Zcp}$ ..... 37

6.5.4.6 Length of bearing factor,  $K_B$  ..... 38

6.5.4.6.1 General..... 38

6.5.4.6.2 Alternative calculation method ..... 38

6.5.5 Tensile resistance parallel to grain ..... 38

6.5.5.1 Factored tensile resistance parallel to grain ..... 38

6.5.5.2 Slenderness ratio for members in tension ..... 39

6.5.6 Stress index due to bending ..... 39

6.5.7 Stress index due to shear ..... 39

6.5.8 Stress index due to compression parallel to grain ..... 39

6.5.9 Stress index due to compression perpendicular to grain..... 39

6.5.10 Stress index due to tension parallel to grain..... 39

6.5.11 Combined stress index due to tension and bending..... 39

6.5.12 Combined stress index due to compression parallel to grain and bending ..... 40

6.5.12.1 General ..... 40

6.5.12.2 Modified formula per Clause 6.5.12 CSA O86-19 ..... 40

6.5.12.2.1 Resistance to combined bending and axial load..... 40

6.5.12.2.2 Bending capacity modification factor,  $K_M$  ..... 40

6.6 Serviceability limit states ..... 41

6.6.1 General ..... 41

6.6.2 Serviceability requirements ..... 41

6.6.3 Permanent deformation .....	43
6.6.4 Ponding .....	43
6.6.5 Top chord bearing trusses with lumber-on-flat .....	43
6.7 Special design considerations .....	43
6.7.1 Overhangs.....	43
6.7.2 Splices.....	43
6.7.2.1 Inner panel splices .....	43
6.7.2.2 Panel point splices .....	43
6.7.2.3 Interference of splices .....	43
6.7.3 Short cantilevers and heel cuts.....	43
6.7.4 Girder trusses (single and multi-ply) .....	44
6.7.4.1 Girder type heels.....	44
6.7.4.1.1 Scarf cuts .....	44
6.7.4.1.2 Design procedures .....	44
6.7.4.2 Ply-to-ply laminating of multi-ply girders trusses .....	44
6.7.5 Truss bracing .....	44
6.7.5.1 General .....	44
6.7.5.2 Lateral brace force for wood truss compression webs .....	44
6.7.6 Top chord bearing guidelines.....	45
6.7.6.1 Lumber-on-edge.....	45
6.7.6.1.1 General.....	45
6.7.6.1.2 Plating requirements for bearing blocks.....	45
6.7.6.2 Lumber-on-flat.....	45
6.7.7 Long-span trusses.....	45
6.7.7.1 General .....	45
6.7.7.2 Trusses with a clear span greater than 30.5 m.....	45
6.7.8 Attic frames .....	46
6.7.8.1 General .....	46
6.7.8.2 Floor vibration of attic frames.....	46
7. Joint Design Procedures .....	46
7.1 General.....	46
7.1.1 Exceptions.....	46
7.1.2 Design assumptions.....	46
7.1.3 Minimum member thickness .....	46
7.1.4 Placement of plates in joints .....	46
7.1.5 Primary axis of truss plates.....	46
7.1.6 Surface area.....	46
7.1.7 Minimum bite for chords and webs .....	47

7.1.7.1 Exceptions.....	47
7.2 Strength resistance of truss plates.....	47
7.2.1 General .....	47
7.2.2 Ultimate lateral resistance of teeth.....	47
7.2.3 Tensile resistance .....	48
7.2.4 Shear resistance .....	48
7.2.5 Lateral slip resistance .....	48
7.3 Ultimate limit states .....	49
7.3.1 General .....	49
7.3.2 Modification factors .....	49
7.3.2.1 Load duration factor, $K_D$ .....	49
7.3.2.2 Service condition factor, $K_{SF}$ .....	49
7.3.2.3 Treatment factor, $K_T$ .....	49
7.3.2.4 Flat roof factor, $K_F$ .....	49
7.3.3 Factored resistance of truss plates .....	49
7.3.3.1 General .....	49
7.3.3.2 Factored ultimate lateral resistance of teeth, $N_r$ .....	50
7.3.3.3 Ultimate lateral resistance of the teeth, $n_u$ .....	50
7.3.3.4 Factored tensile resistance of the plate, $T_r$ .....	51
7.3.3.5 Factored shear resistance of the plate, $V_r$ .....	51
7.4 Serviceability limit states .....	51
7.4.1 General .....	51
7.4.2 Lateral slip resistance .....	51
7.4.2.1 Adjusted lateral slip resistance of the teeth .....	51
7.4.2.2 Lateral slip resistance of the teeth .....	51
7.5 Member joint connections .....	52
7.5.1 Connection of tension members .....	52
7.5.2 Connection of compression members .....	52
7.5.3 Connection of members for shear.....	52
7.5.4 Combined shear-tension resistance .....	52
7.5.5 Net section lumber check, $h'$ .....	53
7.5.6 Tension perpendicular-to-grain considerations.....	53
7.5.7 Heel Joint Considerations .....	54
7.5.8 Chord member splice considerations.....	55
7.5.8.1 General .....	55
7.5.8.2 Tension and/or moment splices .....	55
7.5.8.3 Compression splices .....	55
7.5.8.4 Moment considerations .....	55
7.5.8.4.1 Design of steel section for effect of moment.....	55

7.5.8.4.1.1	Lumber-on-edge.....	56
7.5.8.4.1.2	Lumber-on-edge using combined stress index.....	57
7.5.8.4.1.3	Lumber-on-flat.....	57
7.5.8.4.2	Design of plate lateral resistance for effect of moment.....	58
7.5.9	Compression perpendicular-to-grain reinforcement for sawn lumber.....	59
8.	Manufacturing and material variances .....	60
8.1	General.....	60
8.2	Quality control program.....	60
8.3	Fingerjoined lumber.....	60
9.	Truss design drawings .....	60
Appendix A.....		61
A.1	Analogue joint types .....	61
A.2	Analogue points .....	61
A.2.1	Heel analogue.....	61
A.2.2	Pitch break analogue point.....	62
A.2.3	Splice joint analogue point.....	62
A.2.4	Lapped joint analogue point .....	62
A.2.5	Web joint analogue point.....	62
A.2.6	Internal joint analogue point .....	62
A.2.7	Tail bearing joint analogue point.....	62
A.2.8	Top chord bearing.....	62
A.2.8.1	Top chord bearing joint.....	63
A.2.8.2	Top chord bearing joint with end vertical and block .....	63
A.2.9	Analogue modifications .....	63
A.2.9.1	Analogue heirarchy.....	63
Appendix B.....		72
B.1	General .....	72
B.2	Short cantilever details .....	72
B.2.2	Without reinforcing.....	72
B.2.3	With wedge reinforcing .....	72
B.2.4	With chord reinforcing (Detail B.2.4.A and Detail B.2.4.B).....	72
B.3	Heel Cuts .....	72
B.3.1	Heel cuts $\leq$ half the depth of the bottom chord (Detail A).....	72
B.3.2	Heel cuts $\leq$ the depth of the bottom chord (Detail B) .....	72
B.3.3	Heel cut $>$ the depth of the bottom chord (Detail C).....	72

Appendix C.....	78
Appendix D .....	83
Appendix E.....	84
Appendix F .....	89
F.1 Scope.....	89
F.3 Definitions .....	89
F.4 Shear plate requirements .....	89
F.5 Shear plate design .....	89
Appendix G .....	91
G.1 Scope .....	91
G.2 Truss shop drawing.....	91
G.3 Materials.....	91
G.3.1 Lumber .....	91
G.3.2 Metal connector plates .....	91
G.4 Plating .....	91
G.4.1 Tooth effectiveness .....	91
G.4.1.1 Effective teeth.....	91
G.4.1.2 Ineffective teeth.....	92
G.4.1.2.1 General.....	92
G.4.1.2.2 Fingerjoints.....	92
G.4.1.3 Partially effective teeth .....	92
G.4.1.4 Minimum effective teeth .....	92
G.4.1.4.1 Lumber on edge (wide face plating).....	92
G.4.1.4.2 Lumber on flat (narrow face plating) .....	93
G.4.1.4.3 Joint Stress Index.....	93
G.4.1.5 Tooth flattening.....	93
G.4.1.6 Tooth embedment gap .....	93
G.4.2 Plate placement tolerances.....	94
G.4.2.1 General.....	94
G.4.2.1.1 Lumber on edge .....	94
G.4.2.1.2 Lumber on flat .....	94
G.4.2.2 Translation.....	94
G.4.2.2.1 Lumber on edge .....	94
G.4.2.2.2 Lumber on flat .....	94
G.4.2.3 Rotation .....	95
G.4.2.3.1 Lumber on edge .....	95

G.4.2.3.2 Lumber on flat ..... 95

G.4.2.3 Metal effectiveness..... 95

G.5 Truss assembly ..... 95

G.5.1 Member to member gaps ..... 95

G.5.2 Overall truss dimensions ..... 96

Appendix H..... 97

H.1 General..... 97

## Design Responsibilities

**Truss designer/engineer** - a design professional, individual or organization having responsibility for the design of individual metal plate connected wood truss components, including lateral bracing requirements to prevent buckling of individual truss members due to specified loads.

**Building designer/engineer** - a design professional, individual or organization, having responsibility for overall building design. Within the scope of wood trusses, the building designer/engineer shall specify the following:

- (1) Design loads in accordance with various sections of the National and/or Provincial Building Codes.
- (2) Truss profile and intended support locations.
- (3) Vertical and horizontal deflection limits.
- (4) Moisture environment for intended end use.
- (5) Any special requirements to be considered in the truss design.
- (6) Additional loads from mechanical, electrical units, which may induce extra load to various truss members and their locations.

As this standard does not cover the design for the complete structural system of a building, the building designer/engineer shall provide the following in the design and detailing of the building:

- (1) Truss supports and anchorage accommodating horizontal, vertical or other reaction or displacement.
- (2) Permanent truss bracing to resist wind, seismic and any other lateral forces acting parallel or perpendicular to the plane of trusses.
- (3) Method of connection or anchorage of mechanical, electrical units to various truss members.

## 1. Scope

### 1.1 General

This standard establishes minimum requirements for the design and construction of light metal plate connected wood trusses. This standard describes the materials used in a truss, both lumber and steel, and design procedures for truss members and joints. Manufacturing and material variances and erection tolerances for the trusses are also contained in this standard.

### 1.2 Design method

This standard employs the limit states design method

### 1.3 Terminology

In this standard, “shall” is used to express a requirement, i.e., a provision that the user is obliged to satisfy in order to comply with the standard; “should” is used to express a recommendation or that which is advised but not required; “may” is used to express an option or that which is permissible within the limits of the standard; and “can” is used to express possibility or capability.

## 2. Reference publications

This standard refers to the following publications, and where such reference is made, it shall be to the edition listed below, including all amendments published thereto.

### **APA (The Engineered Wood Association)**

G535

*Field Notching and Drilling of Laminated Veneer Lumber, June 2010 rev*

### **ASTM International (American Society for Testing and Materials)**

A307-14e1

*Standard Specification for Carbon Steel Bolts and Studs, 60 000 psi Tensile Strength*

A653/A653M-18

*Standard Specification for Steel Sheet, Zinc-Coated (Galvanized) or Zinc-Iron Alloy-Coated (Galvanealed) by the Hot-Dip Process*

D5456-18

*Standard Specification for Evaluation of Structural Composite Lumber Products*

### **CCMC (Canadian Construction Materials Centre)**

*Registry of Product Evaluations*

**Note:** See CCMC website.

*Di Lenardo et. al. – Concluding Report – Development of Design Procedures for Vibration Controlled Spans Using Engineered Wood Members, September 4, 1997*

### **CSA Group**

B111-1974 (R2003) (withdrawn)

*Wire nails, spikes and staples*

O86-19

*Engineering Design in Wood*

S347-14

*Method of Test for Evaluation of Truss Plates Used in Lumber Joints*



**CWC (Canadian Wood Council)**

*Wood Design Manual including CSA O86 Standard and CWC Commentary on CSA O86*

**CWTA (Canadian Wood Truss Association)**

*National Quality Standard for Metal Plate Connected Wood Trusses*

**NLGA (National Lumber Grading Authority)**

*Standard Grading Rules for Canadian Lumber (2017), including National Grading Rules for Dimension Lumber*

SPS 1 – 2017

*Special Products Standard for Fingerjoined Structural Lumber*

SPS 2 - 2017

*Special Products Standard for Machine Graded Lumber*

SPS 4 - 2014

*Special Products Standard for Fingerjoined Machine Graded Lumber (FJ-MGL)*

**NRC (National Research Council Canada)**

*National Farm Building Code of Canada 1995*

*National Building Code of Canada 1995*

*National Building Code of Canada 2020*

**SBCA (Structural Building Components Association)**

BCSI Canada

*Guide to Good Practice for Handling, Installing, Restraining & Bracing of Metal Plate Connected Wood Trusses*

**TPIC (Truss Plate Institute of Canada)**

TPIC 1996

*Truss Design Procedures and Specifications for Light Metal Plate Connected Wood Trusses Limit States Design*

TPIC Technical Bulletin #4

*Design for Corrosive Environments (June 2019)*

### **3. Definitions, symbols, abbreviations and units**

#### **3.1 Definitions**

The following definitions apply in this Standard:

**Analogue member** - the line representation of a truss member for the purposes of structural analysis.

**Bearing** - the structural support of the truss, usually load bearing walls, support beams, or truss hangers.

**Bottom chord** - a horizontal or inclined lumber member that establishes the lower edge of a truss.

**Cantilever** - the top and bottom chord section of a truss that extends freely beyond an exterior support.

**Clear span** - the truss length measured from inside face to inside face of adjacent supports.

**Combined stress index (CSI)** – the summation of axial and bending stresses divided by their respective resistances for a specific truss member. The CSI shall not exceed 1.00.

**Companion load** - a specified variable load that accompanies the principal load in a given load combination.

**Companion load factor** - a factor that, when applied to a companion load in the load combination, gives the probable magnitude of a companion load acting simultaneously with the factored principal load.

**Continuous sheathing** - the application of sheathing material to a truss chord, usually by nailing, such that the chord is in effect laterally braced continuously along its length.

**Design span** - the overall length of the truss analogue used in the structural analysis.

**Equilibrium moisture content** – the moisture content at which wood or wood products neither gain nor lose moisture when surrounded by air at a given relative humidity and temperature.

**Factored load** – the product of a specified load and its applicable load factor.

**Factored resistance** – the product of resistance and its applicable resistance factor.

**Flat truss** – a truss in which the slope of the top chord does not exceed 2 in 12.

**Girder truss** – a truss that is used as a main supporting member for secondary framing systems, such as other trusses, joists or rafters.

**Heel joint** - a joint on a truss at which the top and bottom chords intersect.

**Heel cut** - at the heel joint, a vertical cut at the outside edge of the truss bottom chord made to define design span.

**Joint stress index (JSI)** – the ratio of the calculated force in a member to the lateral resistance of the teeth.

**Load sharing systems** - a system consisting of 3 or more essentially parallel trusses spaced not more than 610 mm (1220 mm for low human occupancy) apart and so arranged that they mutually support the applied load.

**Long-span truss** – a truss that has a clear span between bearings greater than 24.4 m.

**Low human occupancy** - (as applying to farm buildings) a building with an occupant load of not more than one person per 40 m<sup>2</sup> during normal use.

**Lumber on edge** - orientation of truss lumber such that the chord sheathing is applied to the least chord dimension and connector plates are embedded into the wider chord dimension.

**Lumber on flat** - orientation of truss lumber such that chord sheathing is applied to the wider chord dimension and connector plates are embedded into the least chord dimension.

**Mid-panel moment** – the maximum moment between panel points.

**Overhang** - the outward extension of one truss chord (usually the top chord) beyond the other chord (usually the bottom chord).

**Panel joint** - the point of intersection where one or more webs meet the top or bottom chord.

**Panel length** – the distance between two adjacent panel points.

**Panel point** – a point representing the intersection of two or more analogue member lines and/or a normal line from a bearing surface.

**Panel point moment** – the moment computed at an analogue panel point.

**Pitch break** - the point at which truss chord lumber changes slopes.

**Principal load** - the specified variable load or rare load that dominates in a given load combination.

**Principal load factor** - a factor applied to a principal load in a load combination to account for the variability of the load and load pattern and the analysis of its effects.

**Sawn lumber** - the product of a sawmill, not further manufactured other than by sawing, re-sawing, passing lengthwise through a standard planning mill and cross-cutting to length.

**Scissor truss** - a type of truss having an inclined bottom chord.

**Serviceability limit states (SLS)** – those states that restrict the intended use and occupancy of a structure. They include deflection, joint slip, vibration and permanent deformation.

**Service load** - the specified load used for the evaluation of a serviceability limit state.

**Service condition** –

**Dry service condition** - a climatic condition in which the average equilibrium moisture content over a year is 15% or less and does not exceed 19%.

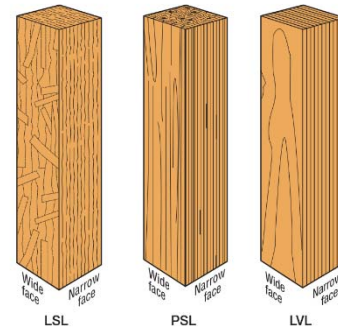
**Wet service condition** – all service conditions other than dry.

**Slope** - the ratio of vertical rise to horizontal run for inclined members.

**Splice joint** - the joint at which two chord members are joined together with truss connector plates to form a single member.

**Structural composite lumber (SCL)** – the wood product that is either laminated veneer lumber (LVL), parallel strand lumber (PSL), laminated strand lumber (LSL) or oriented strand lumber (OSL), as defined in ASTM D5456 and manufactured for use in structural applications. SCL is manufactured with the strands or veneers oriented such that there are two distinct surfaces: the wide face and narrow edge.

**Top chord** - horizontal or inclined lumber member that establishes the upper edge of a truss.



**Truss plate** - a light-gauge metal plate connector, intended for use in structural lumber assemblies that can have integral teeth of various shapes and configurations.

**Truss grade structural composite lumber** – structural composite lumber that is manufactured and identified by the manufacturer for use in truss applications and is subject to quality control testing to verify the lateral resistance of the truss plate teeth.

**Ultimate limit states (ULS)** – those states concerning safety, including the maximum load-carrying capacity, overturning, sliding, fracture and deterioration.

**Webs** - internal truss members that join the top and bottom chords to form triangular patterns that give truss action by carrying axial stresses.

### 3.2 Symbols

The following symbols are used throughout this Standard. Deviations from these usages and additional nomenclature are noted where they appear.

$A$	= cross sectional area, mm <sup>2</sup>
$A_b$	= bearing area, mm <sup>2</sup>
$A'_b$	= average bearing area, mm <sup>2</sup>
$A_{ef}$	= effective plate area on one face of wood member at splice joint, mm <sup>2</sup>
$A_n$	= net cross-sectional area, mm <sup>2</sup>
$b$	= width of member, mm
$C$	= wood compression resistance in a moment splice, MPa
$C_b$	= basic roof snow load factor
$C_C$	= slenderness ratio for compression members
$CL$	= cantilever length, mm
$C_m$	= splice plate moment resistance adjustment factor
$C_{rST}$	= combined factored shear and tension resistance
$C_s, C_w$	= internal compressive force resultants within a moment splice, N
$D$	= diagonal of rectangle equivalent to $A_{ef}$ , mm (Clause 7.5.8.4.2)
$d$	= depth of member, mm
$E$	= specified modulus of elasticity, MPa
$E_{05}$	= modulus of elasticity for design of compression members, MPa
$E_S$	= modulus of elasticity for stiffness calculations, MPa
$f_b$	= specified strength in bending, MPa
$f_c$	= specified strength in compression parallel to grain, MPa
$f_{cp}$	= specified strength in compression perpendicular to grain, MPa
$f_t$	= specified strength in tension parallel to grain at net section, MPa
$f_v$	= specified strength in shear, MPa
$G$	= tooth embedment gap, mm
$F_u$	= specified minimum tensile strength of the steel, MPa
$F_y$	= specified minimum yield strength of the steel, MPa
$h$	= height of equivalent rectangle equal to the greater dimension across $A_{ef}$ , mm
$h'$	= the effective depth of the member based on plate coverage for net section lumber check, mm
$I$	= moment of inertia in the plane of applied moment, mm <sup>4</sup>
$I_E$	= importance factor for earthquake load
$I_S$	= importance factor for snow load
$I_W$	= importance factor for wind load
$J_H$	= moment factor for heel connection
$K$	= blocked tension splice plate effectiveness factor
$K_B$	= length of bearing factor
$K_C$	= slenderness factor for compression members
$K_D$	= load duration factor
$K_e$	= effective length factor
$K_F$	= flat roof factor
$K_H$	= system factor
$K_{Hb}$	= system factor for bending
$K_{Hc}$	= system factor for compression parallel to grain
$K_{Hcp}$	= system factor for compression perpendicular to grain
$K_{HE}$	= system factor for modulus of elasticity
$K_{Ht}$	= system factor for tension parallel to grain
$K_{Hv}$	= system factor for shear
$K_L$	= lateral stability factor for bending members
$K_M$	= bending capacity modification factor

$K_p$	= bearing plate increase factor
$K_S$	= service condition factor for sawn lumber
$K_{Sb}$	= service condition factor for bending
$K_{Sc}$	= service condition factor for compression parallel to grain
$K_{Scp}$	= service condition factor for compression perpendicular to grain
$K_{SE}$	= service condition factor for modulus of elasticity
$K_{SF}$	= service condition factor for truss plates
$K_{St}$	= service condition factor for tension parallel to grain
$K_{Sv}$	= service condition factor for shear
$K_T$	= treatment factor
$K_Z$	= size factor
$K_{Zb}$	= size factor for bending for sawn lumber
$K_{Zc}$	= size factor for compression parallel to grain for sawn lumber
$K_{Zcp}$	= size factor for compression perpendicular to grain for sawn lumber
$K_{ZE}$	= size factor for modulus of elasticity for sawn lumber
$K_{Zt}$	= size factor for tension parallel to grain for sawn lumber
$K_{Zv}$	= size factor for shear for sawn lumber
$L$	= length, mm
$L'$	= distance between projection point and truss point, mm
$LB$	= length of bottom chord reinforcing member, mm
$L_{b1}$	= lesser bearing length, mm (Clause 6.5.4.4)
$L_{b2}$	= larger bearing length, mm (Clause 6.5.4.4)
$L_e$	= effective length, mm
$L_p$	= actual length of members between adjacent panel points or locations of braces or purlins restraining buckling (normally perpendicular to the plane of the truss), mm (Clause 6.5.3.1)
$L_1$	= length of effective steel at the horizontal edge of the member under consideration, mm
$L_2$	= length of effective steel at the vertical edge of the member under consideration, mm
$M_f$	= factored bending moment, N-mm
$M_r$	= factored bending moment resistance, N-mm
$MT$	= length of top chord reinforcing member, mm
$M_{rT}$	= factored moment resistance in combination with tension or compression of a pair of connector plates at a splice joint, N-mm
$M_{rTO}$	= factored moment resistance in combination with tension or compression of a pair of connector plates at a splice joint using $T_f = 0$ , N-mm (Clause 7.5.8.4.1.2)
$M_1$	= maximum factored bending moment between analogue points, N-mm
$M_2$	= maximum of the two factored panel point bending moments, N-mm
$N_{fM}$	= factored lateral stress due to the factored moment on a pair of plates, MPa
$N_{fP}$	= factored lateral stress resultant of factored shear and factored axial loads in wood on a pair of plates equal to the vector addition of the factored shear + factored axial loads in wood divided by $A_{ef}$ , MPa
$N_r$	= factored lateral resistance of the teeth, MPa
$N_{rMIN}$	= minimum factored lateral resistance for any angle of load at the joint for a pair of plates, MPa (Clause 7.5.8.4.2)
$N_{rP}$	= factored lateral resistance stress for a pair of plates for the orientation of $V_f$ , MPa
$N_{rS}$	= lateral slip resistance of the teeth for serviceability limit states, MPa
$n_s$	= lateral slip resistance of the teeth for loads parallel to the primary axis of the plate, MPa
$n'_s$	= lateral slip resistance of the teeth for loads perpendicular to the primary axis of the plate, MPa
$n_u$	= ultimate lateral resistance of the teeth for loads parallel to the primary axis of the plate, MPa
$n'_u$	= ultimate lateral resistance of the teeth for loads perpendicular to the primary axis of the plate, MPa
$OL$	= overhang length, mm
$P$	= factored concentrated load, kN (Clause 7.5.6)
$P_E$	= euler buckling load in plane of applied moment, N
$P_f$	= factored compressive axial load, N
$P_L$	= specified long term-load
$P_S$	= specified standard-term load

$P_r$	= factored compressive resistance parallel to grain, N
$PL$	= panel length, mm
$p_s$	= lateral slip resistance of teeth, MPa
$p'_s$	= lateral slip resistance of teeth, MPa
$p_u$	= ultimate lateral resistance of teeth, MPa
$p'_u$	= ultimate lateral resistance of teeth, MPa
$Q_f$	= factored compressive perpendicular to grain load, N
$Q_r$	= factored compressive resistance perpendicular to grain, N
$Q'_r$	= factored compressive resistance perpendicular to grain for effects of loads applied near a support, N (Clause 6.5.4.3)
$q_s$	= lateral slip resistance of teeth, MPa
$q'_s$	= lateral slip resistance of teeth, MPa
$q_u$	= ultimate lateral resistance of teeth, MPa
$q'_u$	= ultimate lateral resistance of teeth, MPa
$S$	= section modulus, mm <sup>3</sup>
$ST_{rL1}$	= combined factored shear/tension resistance of the pair of metal connector plates through the line of contact L1 (Clause 7.5.4)
$ST_{rL2}$	= combined factored shear/tension resistance of the pair of metal connector plates through the line of contact L2 (Clause 7.5.4)
$s$	= distance from scarf to analogue point, mm (Figures A.2 to A.2.8.2)
$T_f$	= factored axial load in tension, N
$T_{fW}$	= factored tensile force in web, N
$T_r$	= factored tensile resistance parallel to grain, N
$T_r$	= factored tensile resistance of the plate, N/mm
$T_{rp}$	= factored tensile resistance of the pair of plates for use with moment splicing of lumber on flat, N
$T_{rL1}$	= factored tensile resistance perpendicular to the line of action, L1 (Clause 7.5.4)
$T_{rL2}$	= factored tensile resistance perpendicular to the line of action, L2 (Clause 7.5.4)
$t_p$	= tensile resistance of the plate, N/mm
$V_f$	= factored shear force, N
$V_p$	= factored shear resistance of the plate, N/mm
$V_r$	= factored shear resistance, N
$V_{rL1}$	= factored shear resistance parallel to the line of action, L1 (Clause 7.5.4)
$V_{rL2}$	= factored shear resistance parallel to the line of action, L2 (Clause 7.5.4)
$v_p$	= shear resistance of the plate, N/mm
$w$	= width of steel plate perpendicular to the line of force, mm
$w_{br}$	= effective plate width for steel section calculations under effects of moment splices, mm (Clause 7.5.8.2(2))
$X$	= extension of plate above member, mm (Clause 7.5.8.2(2))
$X_f$	= factored axial force in the chord, N
$X_r$	= factored resistance, N (Clause 7.5.8.4.1.2)
$Y$	= moment arm between compression and tension components, mm (Clause 7.5.8.4.1.3)
$y$	= distance from the edge of the chord to the neutral axis of wood steel combination, mm (Clause 7.5.8.4.1.1)
$z$	= distance from compression edge of lumber to compression edge of truss plate, mm
$\phi$	= resistance factor
$\theta$	= angle between load direction and grain
$\theta$	= angle between top and bottom chord
$\theta_1$	= angle between web force direction and line of action L1
$\rho$	= angle between load direction and primary axis of plate

### 3.3 Abbreviations

NFBCC 1995	National Farm Building Code of Canada 1995
NBC 1995	National Building Code of Canada 1995
NBC 2020	National Building Code of Canada 2020
NLGA	National Lumber Grades Authority
TPIC	Truss Plate Institute of Canada

### 3.4 Units

Equations and expressions appearing in this Standard are compatible with the following SI (metric) units:

- (1) force: N (newtons);
- (2) length: mm (millimeters);
- (3) moment: N·mm; and
- (4) strength or stress: MPa (megapascals)

## 4. Materials

### 4.1 Lumber sizes and grades

- (1) Net section properties shall be used for all truss designs.
- (2) Minimum chord and web sizes shall be 38 x 64, except as follows:
  - (a) 38 x 89 for long-span trusses
  - (b) 38 x 89 when using structural composite lumber in accordance with clause 4.1(5)
- (3) With the exception of clauses 4.1(4) and 4.1(5) all trusses shall be manufactured using lumber graded by NLGA rules, with specified strengths per CSA O86-19 and the following shall apply:
  - (a) Top and bottom chords shall be No.2 grade lumber or better
  - (b) Webs of 38 x 64 shall be No.2 grade lumber or better
- (4) Where fingerjoined lumber is used, it shall be produced in accordance with NLGA SPS 1 or NLGA SPS 4.
- (5) Trusses may be manufactured using truss grade structural composite lumber (SCL) provided the following apply:
  - (a) the specified strengths are listed in the manufacturer's product evaluation report and the material is identified by the manufacturer as "Truss Grade Structural Composite Lumber."
  - (b) the member width shall not be greater than 89 mm.
  - (c) Single-pass roller systems shall not be used to manufacture trusses with structural composite lumber.

### 4.2 Steel

#### 4.2.1 General

Truss Plates shall be manufactured from galvanized sheet steel conforming to or exceeding ASTM Standard A653/A653M "Standard specification for Sheet Steel, Zinc coated (Galvanized) by the Hot-Dip Process" and shall have the minimum properties specified in Table 4.2.1.

**Table 4.2.1  
ASTM Specification A653/A653M for Structural Sheet Steel**

Grade	SS230	SS255	SS275	HSLAS340	HSLAS410
Ultimate Tensile Strength, MPa	310	360	380	410	480
Minimum Yield, MPa	230	255	275	340	410
Elongation (at failure) in 50 mm length, %	20	18	16	20	16
Coating Designation	Z275	Z275	Z275	Z275	Z275

#### 4.2.2 Corrosion resistant coatings

Corrosion resistant coatings shall meet the minimum coating designation listed in Table 4.2.1 or shall provide equivalent corrosion protection.

**NOTE:** *It is not necessary to re-coat connectors after stamping. See TPIC Technical Bulletin #4 – Design for Corrosive Environments for additional information.*

#### 4.2.3 Product evaluation reports

All truss plate manufacturers shall have their plates listed in the Registry of Product Evaluations published by Canadian Construction Materials Centre, Institute for Research in Construction, Ottawa, Ontario.

## 5. General design

### 5.1 Specified loads, load effects and load combinations

#### 5.1.1 Loads applied to buildings

The specified loads, load effects and combinations to be considered in the design of a building and its elements shall be those given in Clauses 5.1.3 and 5.1.4. Where these loads are less than the applicable building code, the building code shall govern.

#### 5.1.2 Loads applied to other structures

Where load requirements other than those in Clause 5.1.1 are specified, the appropriateness of the applicable factored resistance in this Standard shall be considered.

### 5.1.3 Specified loads

#### 5.1.3.1 Loads to be considered

Specified loads shall include the following wherever applicable, and minimum specified values of these loads shall be increased to account for dynamic effects where applicable:

- (1) *D* - dead load due to weight of members; the weight of all materials of construction incorporated into the building to be supported permanently by the member, including permanent partitions and allowance for non-permanent partitions; the weight of permanent equipment;
- (2) *D<sub>s</sub>* - dead load due to the weight of soil, superimposed earth, plants and trees
- (3) *E* - load due to earthquake including the effect of the importance factors in 5.1.3.2;
- (4) *L* - live load due to intended use and occupancy including loads due to cranes and pressure of liquids in containers;
- (5) *S* - load due to snow, including ice and associated rain, and also including the effect of the importance factors in 5.1.3.2;
- (6) *W* - load due to wind including the importance factors in 5.1.3.2;
- (7) *H* - a permanent load due to lateral earth pressure, including groundwater;



- (8) *P* - permanent effects caused by pre-stress; and
- (9) *T* - loads due to contraction or expansion caused by temperature changes, shrinkage, moisture changes, creep in component materials, movement due to differential settlement, or combinations thereof.

**Note:** See NBC 2020 for information on crane loads.

### 5.1.3.2 Importance category

For the purpose of determining specified loads *S*, *W* or *E* in Clauses 5.2.1 and 5.2.2, buildings shall be assigned an Importance Category based on intended use and occupancy, in accordance with Table 5.1.3.2.

**Table 5.1.3.2  
Importance categories for buildings**

Use and Occupancy	Importance Category
Buildings that represent a low direct or indirect hazard to human life in the event of failure, including: <ul style="list-style-type: none"> <li>▪ Low human-occupancy buildings, where it can be shown that collapse is not likely to cause injury or other serious consequences</li> <li>▪ Minor storage buildings</li> </ul>	Low
All buildings except those listed in Importance Categories Low, High and Post Disaster	Normal
Buildings that are likely to be used as post-disaster shelters, including buildings whose primary use is: <ul style="list-style-type: none"> <li>▪ As an elementary, middle or secondary school</li> <li>▪ As a community centre</li> </ul> Manufacturing and storage facilities containing toxic, explosive or other hazardous substances in sufficient quantities to be dangerous to the public if released.	High
Post-disaster buildings are buildings that are essential to the provision of services in the event of a disaster, and include: <ul style="list-style-type: none"> <li>▪ hospitals, emergency treatment facilities and blood banks</li> <li>▪ telephone exchanges</li> <li>▪ power generating stations and electrical substations</li> <li>▪ control centres for air, land and marine transportation</li> <li>▪ public water treatment and storage facilities, and pumping stations</li> <li>▪ sewage treatment facilities and buildings having critical national defence functions</li> <li>▪ buildings of the following types, unless exempted from this designation by the authority having jurisdiction:                             <ul style="list-style-type: none"> <li>▪ emergency response facilities</li> <li>▪ fire, rescue and police stations, and housing for vehicles, aircraft or boats used for such purposes</li> <li>▪ communications facilities, including radio and television stations</li> </ul> </li> </ul>	Post- disaster

### 5.1.3.3 Importance factors

For the purpose of determining specified loads *S*, *W*, or *E* in Clause 5.1.3.1, Importance Factors shall be applied in accordance with Table 5.1.3.3

**Table 5.1.3.3**  
**Importance factors for determining S, W or E loads**

Importance Category	Importance Factors for Snow Loads, $I_s$		Importance Factors for Wind Loads, $I_w$		Importance Factors for Earthquake Loads, $I_E$	
	Ultimate Limit State	Serviceability Limit State	Ultimate Limit State	Serviceability Limit State	Ultimate Limit State	Serviceability Limit State
Low	0.8	0.9	0.8	0.75	0.8	N / A
Normal	1.0	0.9	1.0	0.75	1.0	N / A
High	1.15	0.9	1.15	0.75	1.3	N / A
Post Disaster	1.25	0.9	1.25	0.75	1.5	N / A

**Note:** The Importance Factor for snow ( $I_s$ ) does not apply to Part 9 designs.

## 5.1.4 Load combinations

### 5.1.4.1 Load combinations for ultimate limit states

The effect of factored principal plus companion loads shall be determined in accordance with the load combinations in Table 5.1.4.1, the applicable combination being that which produces the most unfavourable effect.

**Table 5.1.4.1**  
**Load combinations for ultimate limit states**

Case No.	Principal Loads <sup>(1)</sup>	Companion Loads
1	$1.4D + 1.5D_s$	-
2	$(1.25D + 1.5D_s \text{ or } 0.9D + 0.9D_s) + 1.5L^{(3)}$	$1.0S^{(2)}$ or $0.4W$
3	$(1.25D + 1.5D_s \text{ or } 0.9D + 0.9D_s) + 1.5S$	$1.0L^{(2,4)}$ or $0.4W$
4	$(1.25D + 1.5D_s \text{ or } 0.9D + 0.9D_s) + 1.4W$	$0.5L^{(4)}$ or $0.5S$
5	$1.0D + 1.0D_s + 1.0E$	$0.5L^{(2,4)} + 0.25S^{(2)}$

(1) Refer to the NBC 2020 for loads due to earth pressure  $H$ , pre-stress  $P$  and imposed deformation  $T$ .

(2) Refer to the NBC 2020 for loads on exterior areas.

(3) The Principal load factor 1.5 for live load  $L$  may be reduced to 1.25 for liquids in tanks.

(4) The companion load factor for live load  $L$  shall be increased by 0.5 for storage occupancies, equipment areas and service rooms.

### 5.1.4.2 Load combinations for serviceability limit states

The effect of principle plus companion loads shall be determined in accordance with the load combinations in Table 5.1.4.2, the applicable combination being that which results in the most unfavourable effect.

**Table 5.1.4.2**  
**Load combinations for serviceability limit states**

Case No.	Principal Loads	Companion Loads
1	$1.0D^{(1)}$	-
2	$1.0D^{(1)} + 1.0L$	$0.5S^{(2)}$ or $0.4W$
3	$1.0D^{(1)} + 1.0S$	$0.5L^{(2)(3)}$ or $0.4W$
4	$1.0D^{(1)} + 1.0W$	$0.5L^{(3)}$ or $0.5S$

- (1) Dead loads to include permanent loads due to lateral earth pressure  $H$  and pre-stress  $P$ .  
 (2) Refer to the NBC 2020, for loads on exterior areas.  
 (3) The companion load factor of 0.5 for a live load ( $L$ ) shall be increased to 1.0 for storage occupancies, equipment areas and service rooms.

## 5.2 Specified snow, live and wind loads

### 5.2.1 Roof trusses

#### 5.2.1.1 Part 9 of NBC 2020

- (1) Roof trusses meeting the housing and small building requirements of Part 9 of the NBC 2020, with clear spans between bearings less than or equal to 12.2 m shall be designed using a roof snow load not less than 55% of the appropriate ground snow load plus rain load as listed in the NBC 2020 Division B, Appendix C. When the entire width of roof does not exceed 4.3 m this 55% can be reduced to 45%.
- (2) Roof trusses meeting the housing and small building requirements of Part 9 of the NBC 2020, with clear spans between bearings greater than 12.2 m shall be designed as per clause 5.2.1.2.
- (3) The minimum specified top chord snow load shall be 1.0 kPa.
- (4) Multi-bearing trusses shall be designed for pattern-loading.
- (5) Where the 1-in-50 hourly wind pressure is greater than 0.8 kPa, roof trusses shall be tied to the wall framing with connectors that will resist a factored uplift load of 3 kN.

#### 5.2.1.2 Part 4 of NBC 2020

- (1) Roof trusses designed under the requirements of Part 4 of NBC 2020 shall be designed using a roof snow load not less than 80% of the appropriate ground snow load plus rain load as listed in NBC 2020 Division B, Appendix C, except where:
  - (a) Wind exposure conditions specified by sentence 4.1.6(4) of NBC 2020 are fulfilled, hence 60% of the ground snow load plus rain load may be used as the roof snow load for low and normal building importance, or
  - (b) The roof slope is greater than 30 degrees, hence the roof snow load can be reduced by a slope factor as specified by sentence 4.1.6(5) of NBC 2020, or
  - (c) The roof slope is greater than 15 degrees and slippery roof conditions specified by sentence 4.1.6(6) of NBC 2020 are fulfilled, hence the roof snow load can be reduced by a slope factor as specified in that subsection, or
  - (d) For large roofs the value of  $C_b$  shall be calculated per sentence 4.1.6.2(2) of NBC 2020.
  - (e) The snow load is specified in writing by an authority having jurisdiction.
- (2) Roof trusses shall be designed to meet the requirements of full and partial loading as specified by subsections 4.1.5 and 4.1.6 of NBC 2020.
- (3) Roof trusses shall be designed to meet the requirements of unbalanced, sliding and drifting snow loads, as given in subsection 4.1.6 of NBC 2020.
- (4) Roof trusses with slopes of 15 degrees or less need not be designed for unbalanced snow loads.
- (5) The minimum specified top chord snow load shall be 1.0 kPa. The minimum specified live load for attics with limited accessibility shall be 0.5 kPa as per Table 4.1.5.3 of NBC 2020 unless specified otherwise by an authority having jurisdiction.

- (6) Roof trusses shall be designed for wind loading in accordance with subsection 4.1.7 of NBC 2020.
- (7) For wind analysis the minimum reference velocity pressure shall be based on the probability of being exceeded once in 50 years for strength and deflection. Appropriate wind loads are as listed in NBC 2020 Division B, Appendix C.

### **5.2.1.3 National Farm Building Code of Canada 1995 - Low human occupancy**

Roof trusses meeting the low human occupancy requirements of the NFBC 1995:

- (1) shall be designed using a roof live load not less than 80% of the appropriate ground snow load plus rain load as listed in NBC 1995 Appendix C, except where:
  - (a) Wind exposure conditions specified by subsection 4.1.7 of NBC 1995 are fulfilled, hence 60% of the ground snow load plus rain load may be used as the roof load, or
  - (b) The roof slope is greater than 30 degrees, hence the roof snow load can be reduced by a slope factor as specified by subsection 4.1.7 of NBC 1995, or
  - (c) The roof slope is greater than 15 degrees and slippery roof conditions specified by article 2.2.2.2 of NFBC 1995 are fulfilled, hence the roof snow load can be reduced by a slope factor as specified in that section, or
  - (d) The snow load is specified in writing by an authority having jurisdiction.
- (2) shall be designed to meet the requirements of unbalanced, sliding and drifting snow loads as given in subsection 4.1.7 of NBC 1995.
- (3) with slopes of 15 degrees or less need not be designed for unbalanced snow loads per article 2.2.2.1 of NFBC 1995.
- (4) shall have a minimum specified top chord live load of 1.0 kPa.
- (5) shall be designed for wind load in accordance to subsection 4.1.8 of NBC 1995 using a minimum reference velocity pressure based on the probability of being exceeded once in 10 years.

## **5.2.2 Floor trusses**

### **5.2.2.1 Part 9 of NBC 2020**

- (1) The minimum residential specified floor live load shall be 1.9 kPa.
- (2) Floor trusses must be designed to satisfy the most critical loading conditions of full or partial loading.

### **5.2.2.2 Part 4 of NBC 2020**

- (1) The minimum specified live load shall be as per Table 4.1.5.3 of NBC 2020
- (2) Floor trusses must be designed to satisfy the most critical loading conditions of full or partial loading.
- (3) The specified load due to possible concentrations of loads resulting from the use of area of floors, shall not be less than that listed in Table 4.1.5.9 of NBC 2020.

### **5.2.2.3 Vibration**

Floor trusses shall be designed to minimize the effects of vibration in accordance with the provisions outlined in CCMC *“Concluding Report – Development of Design Procedures for Vibration Controlled Spans Using Engineered Wood Members”* (see Reference Publications). Special considerations should be made when designing floors with concrete topping.

## **5.3 Specified dead loads**

### **5.3.1 Roof dead loads**

The minimum dead loads specified in Table 5.3.1 shall be used for all designs unless specified by an authority having jurisdiction. In no case shall the specified dead load be less than the actual applied load.

**Table 5.3.1**  
**Minimum dead loads, kPa**

Occupancy	TC Dead Load		BC Dead Load	
	<1:6 (2/12)	>1:6 (2/12)	With Ceiling	Without Ceiling
Residential (Part 9)	0.5	0.25	0.35	N/A
Commercial (Part 4)	0.5	0.25	0.35	0.25
Farm (Part 4)	0.5	0.20	0.35	0.20

**Note:** The designer should check the suitability of the tabulated minimums for their applications

### 5.3.2 Floor dead loads

The minimum dead loads specified below shall be used for all designs unless specified otherwise by an authority having jurisdiction. In no case shall the specified dead load be less than the actual applied load.

- (1) The minimum top chord dead load shall be 0.5 kPa.
- (2) The minimum bottom chord dead load shall be 0.25 kPa.
- (3) In areas of a building where partitions, other than permanent partitions shown on design drawings, or, where partitions might be added in the future, allowance shall be made for the weight of such partitions.
  - (a) The partition weight allowance for the above shall be determined from the actual or anticipated weight of the partitions placed in any probable position, but shall not be less than 1.0 kPa over the area of floor being considered.
- (4) A non-bearing partition wall may be neglected in the design, provided:
  - (a) the live load of the supporting truss system results from residential occupancy and is not less than specified in Clause 5.2.2.1.
  - (b) floor trusses are not spaced over 610 mm o/c.
  - (c) the top chord panel length of supporting truss system does not exceed 750 mm for lumber-on-flat trusses.
  - (d) the partition weight does not exceed 0.88 kN/m.
  - (e) the partition wall is not parallel to the trusses.

## 6. Member design procedures

### 6.1 Method of analysis

Structural analysis shall be by stiffness or flexibility method utilizing pin-rigid mathematical model.

#### 6.1.1 Truss analogue

Trusses shall be modeled using the analogue points detailed in Appendix A.

#### 6.1.2 Truss model

- (1) All chord members shall be rigidly connected through joints, including web joints and lapped joints. All splices shall be considered pinned unless designed for moment. Fictitious members representing top and bottom chords at the heel shall be pinned to each other but rigidly connected at other end.
- (2) Ends of members connecting to pitch break joints shall be considered pinned at the joints.
- (3) The fictitious vertical strut at heel shall be pinned to top and bottom chords.
- (4) Properties of fictitious members shall be as follows:
  - (a) A top chord fictitious member shall have the same properties as the adjacent top chord.
  - (b) A bottom chord fictitious member shall have the same properties as the adjacent bottom chord.
  - (c) Other fictitious members shall have the properties of 2x4 S-P-F No.1/No.2 lumber.

- (5) Fictitious members in top chord bearing conditions such as in Clause A.2.8.2 shall be pinned at both ends and have properties of 2x4 S-P-F No.1/No.2 lumber.
- (6) Overhangs shall be modelled and analysed as members of the truss component and not as an independent cantilever with a rigid support and may not be modified in the field unless analysed for the modified condition (this includes cutting or extending).

### 6.1.3 Support model

Except for the leftmost support, all supports shall be considered as horizontal or vertical rollers. The leftmost support must be pinned. No support shall be considered to provide rotational restraint unless such restraint is adequately specified on the drawing. At a heel joint the support shall be located at the first analog point (the outermost joint). Except at heel joints, a support is considered to be at a joint when there is an overlap between contact surfaces of bearing and webs. A support is considered to be at the heel joint if the heel condition is to be used with short cantilever rules. See Clause 6.7.3.

### 6.1.4 Member forces and moments

- (1) Member force shall be the average of the member end forces. Member force for connections shall be the actual member forces at the joint.
- (2) Panel moment shall be taken as the maximum moment within the panel. Panel point moment shall be that at each individual panel end.
- (3) Combined Stress index shall be calculated for the panel on the basis of CSI from average member force combined with the greater of maximum panel moment or the maximum panel point moment.

### 6.2 Ultimate limit states

The design of truss members for ultimate limit states shall include:

- (1) Establishing the value of the effect of the factored loads individually and with the load combinations specified in Clause 5.1.4.1; and
- (2) Confirmation by rational means that for each load effect in item (1), the factored load effect does not exceed the factored resistance, as determined by appropriate clauses of this standard.

### 6.3 Serviceability limit states

The design of truss members for serviceability limit states shall include:

- (1) Establishing the value of the effect of the specified loads individually and with the load combinations specified in Clause 5.1.4.2; and
- (2) Confirmation by rational means that for each load effect in item (1), the structural effect falls within the limits specified in the appropriate clauses of this standard.

### 6.4 Specified strengths

#### 6.4.1 Visually stress-graded lumber

The specified strengths for visually stress-graded structural joist and planks, light framing, structural light framing and stud grade categories of lumber shall be those presented in Table 6.4 and Table 6.5 of CSA O86-19.

#### 6.4.2 Machine stress-rated and machine evaluated lumber

The specified strengths for machine stress-rated lumber are given in Table 6.8 of CSA O86-19. The specified strengths for machine evaluated lumber are given in Table 6.9 CSA O86-19. The specified strengths in shear are not grade dependent and shall be taken from Table 6.4 of CSA O86-19 for the appropriate species.

#### 6.4.3 Structural composite lumber

The specified strengths for structural composite lumber shall be calculated in accordance with Clause 16.3 of CSA O86-19.

## 6.4.4 Conditions and factors affecting resistance

### 6.4.4.1 General

Specified strengths and capacities in this Standard are based on the standard-term duration of loads, dry-service conditions, and untreated materials. Specified strengths and capacities for materials and connectors shall be modified by the modification factors in this Clause and the appropriate materials or connector Clauses of this standard.

### 6.4.4.2 Load duration factor, $K_D$

#### 6.4.4.2.1 General

The specified strengths and resistances shall be multiplied by a load duration factor,  $K_D$ , in accordance with Table 6.4.4.2 or calculated per Clause 6.4.4.2.2.

**Table 6.4.4.2**  
**Load duration factor,  $K_D$**

Duration of Load	$K_D$	Explanatory Notes
Short term	1.15	Short term loading means that condition of loading where the duration of the specified loads is not expected to last more than 7 days continuously or cumulatively throughout the life of the structure. Examples include wind loads, earthquake loads, impact loads, falsework, and formwork, as well as standard and/or long-term loads in combination with the above.
Standard term	1.00	Standard term means that condition of loading where the duration of specified loads exceeds that of short term loading, but is less than long term loading. Examples include snow loads, live loads due to occupancy, wheel loads on bridges, and dead loads in combination with the above.
Long term	0.65	Long term duration means the condition of loading under which a member is subjected to continuous specified load. Examples include dead loads or dead loads plus live loads of such character that they are imposed on the member for as long as the dead loads themselves. Such loads include those usually occurring in tanks or bins containing fluids or granular material, loads on retaining walls subjected to lateral pressure such as earth, and floor loads where the specified load can be expected to be continuously applied, such as those in buildings for storage of bulk materials. Loads due to fixed machinery are considered long term.

**Note:** Load duration requires professional judgement by the designer. Explanatory notes in this table provide guidance to designers about the types of loads and load combinations for which each modification factor should be applied.

#### 6.4.4.2.2 Long term load duration factor

Where the specified long-term load,  $P_L$ , is greater than the specified standard-term load  $P_S$ , a load factor of 0.65 may be used or  $K_D$  may be calculated as follows:

$$K_D = 1.0 - 0.50 \log (P_L / P_S) \geq 0.65$$

where:

$P_L$  = specified long-term load

$P_S$  = specified standard term load based on  $S$  and  $L$  loads acting alone or in combination  
 =  $S$ ,  $L$ ,  $S + 0.5L$ , or  $0.5S + L$ , determined using importance factors equal to 1.0

#### 6.4.4.2.3 Structural composite lumber

The load duration factor,  $K_D$ , indicated in Clause 6.4.4.2 is applicable to the specified strengths of structural composite lumber products, provided that appropriate testing demonstrating the validity of the factor for use with the applicable structural composite lumber product has been conducted.

**Note:** See the CWC Commentary on CSA O86

#### 6.4.4.3 Service condition factor, $K_S$

##### 6.4.4.3.1 Sawn lumber

The specified strength and modulus of elasticity for sawn lumber shall be multiplied by a service condition factor  $K_S$ , as indicated in Table 6.4.4.3.

**Table 6.4.4.3**  
**Service Condition Factors,  $K_S$**

$K_S$	Property	Wet service	Dry service
$K_{Sb}$	Bending at extreme fibre	0.84	1.0
$K_{Sv}$	Longitudinal shear	0.96	1.0
$K_{Sc}$	Compression parallel to grain	0.69	1.0
$K_{Scp}$	Compression perpendicular to grain	0.67	1.0
$K_{St}$	Tension parallel to grain	0.84	1.0
$K_{SE}$	Modulus of elasticity	0.94	1.0

**Note:** Long-span Trusses shall only be used in dry service conditions (see Clause 6.7.7)

##### 6.4.4.3.2 Structural composite lumber

The specified strengths and stiffness of structural composite lumber products are applicable for use in dry service conditions, with  $K_S = 1.0$ . If structural composite lumber products are to be used in other than dry service conditions, consideration shall be given to the choice of adhesive and the specified strength and stiffness shall be evaluated. This shall include development of appropriate strength reduction factors, based on documented test results, determined in accordance with the manufacturer's product evaluation report.

#### 6.4.4.4 Preservative and fire-retardant treatment factor, $K_T$

##### 6.4.4.4.1 Preservative-treated lumber

The specified strength of preservative-treated unincised lumber shall be multiplied by the treatment factor,  $K_T = 1.0$ . Preservative treated incised lumber shall not be used under this standard.

##### 6.4.4.4.2 Fire retardant or other strength reducing chemicals

For lumber treated with fire-retardant or other strength reducing chemicals, strength and stiffness capacities shall be based on the documented results of tests that shall take into account the effects of time, temperature and moisture content in accordance with Clause 4.3.2. of CSA O86-19.



#### 6.4.4.4.3 Structural composite lumber

The specified strengths and stiffness of structural composite lumber products are applicable to untreated lumber only, with  $K_T = 1.0$ . Treatment adjustments for specified strengths and stiffness of structural composite lumber products shall be based on the documented results of tests that take into account the effects of time, temperature and moisture content, determined in accordance with the manufacturer's product evaluation report.

#### 6.4.4.4.5 System factor, $K_H$

Specified strengths for sawn lumber or structural composite lumber members in a light frame truss system consisting of three or more essentially parallel members spaced not more than 610 mm apart and so arranged that they mutually support the applied load may be multiplied by the system factor given in Table 6.4.4.5.

**Table 6.4.4.5**  
**System factor,  $K_H$**

Symbol	Property	$K_H$	
		Sawn Lumber	SCL
$K_{Hb}$	Bending	1.10	1.04
$K_{Hv}$	Longitudinal shear	1.10	1.00
$K_{Hc}$	Compression parallel to grain	1.10	1.00
$K_{Hcp}$	Compression perpendicular to grain	1.00	1.00
$K_{Ht}$	Tension parallel to grain	1.10	1.00
$K_{HE}$	Modulus of elasticity	1.00	1.00

**Note:** These system factor increases are also applicable when spacing does not exceed 1220 mm for farm buildings of low human occupancy and for all girders consisting of not less than 3 members.

#### 6.4.4.6 Size factor, $K_z$

##### 6.4.4.6.1 Visually stress-graded lumber

Except as provided in Clause 6.4.4.6.2, the specified strengths of visually stress-graded lumber shall be multiplied by a size factor,  $K_z$ , in accordance with Table 6.4.4.6.

**Note:** See Table 6.13 CSA O86-19 for additional size factors.

##### 6.4.4.6.2 Light framing grades

The size factor,  $K_z$ , for light-framing grades shall be 1.0, except that  $K_{zc}$  and  $K_{zcp}$  shall be as shown in Table 6.4.4.6.

##### 6.4.4.6.3 Machine stress-rated and machine evaluated lumber

The size factor,  $K_z$ , for MSR or MEL lumber shall be 1.0, except that  $K_{zv}$ ,  $K_{zcp}$  and  $K_{zc}$  shall be as shown in Table 6.4.4.6.

##### 6.4.4.6.4 Structural composite lumber

The size factor,  $K_z$ , for structural composite lumber products shall be 1.0 except that  $K_{zb}$  and  $K_{zt}$  shall be determined in accordance with the manufacturer's product evaluation report using an effective length equal to 6096 mm.

**Table 6.4.4.6**  
**Size factor,  $K_Z$ , for visually stress-graded lumber**

Symbol	Description	Lumber Size (mm) 38 x						
		64	89	114	140	184	235	286
$K_{Zb}$	Bending	1.7	1.7	1.5	1.4	1.2	1.1	1.0
$K_{Zv}$	Longitudinal shear	1.7	1.7	1.5	1.4	1.2	1.1	1.0
$K_{Zc}$	Compression parallel to grain	*	*	*	*	*	*	*
$K_{Zcp}$	Compression perpendicular to grain	**	**	**	**	**	**	**
$K_{Zt}$	Tension parallel to grain	1.5	1.5	1.4	1.3	1.2	1.1	1.0
$K_{ZE}$	Modulus of elasticity	1.0	1.0	1.0	1.0	1.0	1.0	1.0

\* See Clause 6.5.3

\*\* See Clause 6.5.4

#### 6.4.4.7 Flat roof factor, $K_F$

Roof trusses meeting the housing and small building requirements of Part 9 of the NBC 2015 and carrying flat roof (where roof portion with slope < 1:6 exceeds 50% of building width) shall be designed with a reduced factored resistance strength of lumber by applying a flat roof factor  $K_F = 0.75$ . For all other cases  $K_F = 1.0$ .

### 6.5 Strength and resistance

Clause 6.5 specifies design data and methods that apply to sawn lumber and structural composite lumber of rectangular cross-section.

#### 6.5.1 Bending moment resistance

##### 6.5.1.1 Factored bending moment resistance

The factored bending moment resistance,  $M_r$ , shall be calculated as follows:

$$M_r = \phi F_b S K_{Zb} K_L K_F$$

where:

$$\phi = 0.9$$

$$F_b = f_b (K_D K_{Hb} K_{Sb} K_T)$$

$f_b$  = specified strength in bending, MPa (Tables 6.4 and 6.5 or Clause 16.3 of CSA O86-19)

$S$  = section modulus, mm<sup>3</sup> (see note below)

$K_{Zb}$  = size factor in bending (Clause 6.4.4.6)

$K_L$  = lateral stability factor (Clause 6.5.1.2)

$K_F$  = flat roof factor (Clause 6.4.4.7)

**Note:** when calculating the section modulus of structural composite lumber members, the effective width of the board shall be further reduced by 5 mm when metal truss plates with tooth lengths greater than 9.5 mm are pressed into the member.

### 6.5.1.2 Lateral stability factor, $K_L$

The lateral stability factor,  $K_L$ , may be taken as unity when lateral support is provided at points of bearing to prevent lateral displacement and rotation and the provisions of Table 6.5.1.2 are met.

**Note:** Alternatively,  $K_L$  may be calculated in accordance with Clause 7.5.6.4 of CSA O86-19.

**Table 6.5.1.2**  
**Lateral stability factor,  $K_L=1.0$**

Member Size	Support Condition
38 x 64 38 x 89 38 x 114 38 x 140	No additional intermediate support is required.
38 x 184	The member is held in line by purlins.
38 x 235	The compressive edge is held in line by direct connection of sheathing or purlins spaced not more than 610 mm apart.
38 x 286	The compressive edge is held in line by direct connection of sheathing or purlins spaced not more than 610 mm apart and adequate bridging or blocking is installed at intervals not exceeding 2280 mm.

### 6.5.2 Shear resistance

The factored shear resistance,  $V_r$ , shall be calculated as follows:

$$V_r = \phi F_v \frac{2A_n}{3} K_{Zv} K_F$$

where:

$$\phi = 0.9$$

$$F_v = f_v K_D K_{Hv} K_{Sv} K_T$$

$f_v$  = specified strength in shear, MPa (Tables 6.4 and 6.5 or Clause 16.3 of CSA O86-19)

$K_{Zv}$  = size factor in shear (Clause 6.4.4.6)

$A_n$  = net area of cross-section, mm<sup>2</sup>

$K_F$  = flat roof factor (Clause 6.4.4.7)

### 6.5.3 Compressive resistance parallel to grain

#### 6.5.3.1 Effective length

Unless noted otherwise, the effective length  $L_e = K_e L_p$  shall be used in determining the slenderness ratio of truss compression members.

Where:

$K_e = 0.8$  for buckling between adjacent panel points in the truss

$K_e = 1.0$  for buckling between brace or purlin locations on the truss

$L_p$  = actual length of member between adjacent analogue panel points, or; locations of braces or purlins restraining buckling (normally perpendicular to the plane of the truss). For design of truss webs the longest cutting length shall be used.

**Note:** Other recommended effective length factors,  $K_e$ , for compression members can be found in Clause A.6.5.5.1 of CSA O86-19.

### 6.5.3.2 Simple compression members - constant rectangular cross-section

The slenderness ratio,  $C_c$ , of simple compression members of constant rectangular section shall not exceed 50 and shall be calculated for both axes as follows:

$$C_c = \frac{\text{effective length associated with width}}{\text{member width}}$$

$$C_c = \frac{\text{effective length associated with depth}}{\text{member depth}}$$

### 6.5.3.3 Factored compressive resistance parallel to grain

The factored compressive resistance parallel to grain,  $P_r$ , shall be calculated as follows:

$$P_r = \phi F_c A K_{Zc} K_c K_F$$

where:

$$\phi = 0.8$$

$$F_c = f_c (K_D K_{Hc} K_{Sc} K_T)$$

$f_c$  = specified strength in compression parallel to grain, MPa (Tables 6.4 and 6.5 or Clause 16.3 of CSA O86-19)

$$K_{Zc} = 6.3(dL)^{-0.13} \leq 1.3 \text{ for sawn lumber}$$

$$= 1.0 \text{ for structural composite lumber}$$

$K_F$  = flat roof factor (Clause 6.4.4.7)

$d$  = dimension in direction of buckling (depth or width), mm

$L$  = length associated with member dimension, mm

**Note:** The member length,  $L$ , used to compute the factor  $K_{Zc}$  shall be the greater of the panel length or one-half the chord length between pitch breaks for chord design and shall be the longest cutting length or the analogue length for web design.

### 6.5.3.4 Slenderness factor, $K_c$

For both axes, the slenderness factor,  $K_c$ , shall be calculated as follows:

$$K_c = \left\{ 1.0 + \frac{F_c K_{Zc} C_c^3}{35 E_{05} K_{SE} K_T} \right\}^{-1}$$

where:

$$E_{05} = 0.82E \text{ for MSR lumber}$$

$$= 0.75E \text{ for MEL lumber}$$

$$= 0.87E \text{ for SCL}$$

= as specified in Tables 6.4 and 6.5 of CSA O86-19, for visually stress-graded lumber

## 6.5.4 Compressive resistance perpendicular to grain

### 6.5.4.1 General

Factored bearing forces shall not exceed the factored compressive resistance perpendicular to grain determined in accordance with Clauses 6.5.4.2 and 6.5.4.3.

### 6.5.4.2 Effect of all applied loads

The factored compressive resistance perpendicular to grain,  $Q_r$ , under the effect of all factored applied loads shall be calculated as follows:

$$Q_r = \phi F_{cp} A_b K_B K_{Zcp} K_p$$

where:

$$\phi = 0.8$$

$$F_{cp} = f_{cp}(K_D K_{Scp} K_T)$$

$f_{cp}$  = specified strength in compression perpendicular to grain, MPa  
(Tables 6.4 and 6.5 or Clause 16.3 of CSA O86-19)

$A_b$  = bearing area, mm<sup>2</sup>

$K_B$  = length of bearing factor (Clause 6.5.4.6)

$K_{Zcp}$  = size factor for bearing (Clause 6.5.4.5)

$K_p$  = bearing plate increase factor = 1.18 when the truss plate, with minimum width of 3", is located over bearing such that the lower edge of the plate is flush with the lower edge of truss chord and the plate length covers the entire bearing length.  $K_p$  is applicable to sawn lumber on edge only. For structural composite lumber or sawn lumber on flat,  $K_p = 1.0$

**Note:** For sawn lumber, the requirements of Clause 6.5.4.2 may be met by providing adequate bearing reinforcement against the effects of concentrated bearing loads acting near a support. See Clause 7.5.9

### 6.5.4.3 Effects of loads applied near a support

The factored compressive resistance perpendicular to grain,  $Q'_r$ , under the effect of only those factored loads applied within a distance from the centre of the support equal to the depth of the member, shall be taken calculated as follows:

$$Q'_r = (2/3) \phi F_{cp} A'_b K_B K_{Zcp} K_p$$

where:

$$\phi = 0.8$$

$$F_{cp} = f_{cp}(K_D K_{Scp} K_T)$$

$A'_b$  = average bearing area (Clause 6.5.4.4)

### 6.5.4.4 Unequal bearing areas on opposite surfaces of a member

Where unequal bearing areas are used on opposite surfaces of a member, the average bearing area shall be calculated as follows:

$$A'_b = b \left\{ \frac{L_{b1} + L_{b2}}{2} \right\}, \text{ but } \leq 1.5b(L_{b1})$$

where:

$b$  = average bearing width (perpendicular to grain), mm

$L_{b1}$  = lesser bearing length, mm

$L_{b2}$  = larger bearing length, mm

### 6.5.4.5 Size factor for bearing, $K_{Zcp}$

For sawn lumber used on flat, as opposed to on edge, the compression resistance perpendicular to grain may be multiplied by a size factor for bearing,  $K_{Zcp}$ , in accordance with Table 6.5.4.5.

**Table 6.5.4.5**  
**Size factor for bearing,  $K_{ZCP}$**

Ratio of Member Width To Member Depth*	$K_{ZCP}$
1.0 or Less	1.00
2.0 or More	1.15

\* Interpolation applies to intermediate ratios.

**Note:** The use of structural composite lumber in lumber-on-flat applications is restricted in accordance with Clause 7.1.1(3), where pressing of plates into the narrow edge of SCL shall be approved by the manufacturer.

### 6.5.4.6 Length of bearing factor, $K_B$

#### 6.5.4.6.1 General

When lengths of bearing are less than 150 mm, specified strengths in compression perpendicular to grain may be multiplied by a length of bearing factor in accordance with Clause 6.5.4.6.2 or Table 6.5.4.6 provided that:

- (1) no part of the bearing area is less than 75 mm from the end of the members; and
- (2) bearing areas do not occur in positions of high bending stresses.

**Table 6.5.4.6**  
**Length of bearing factor,  $K_B$**

Bearing Length ( $L_b$ ) Measured Parallel To Grain (mm)	$K_B$
12.5 and Less	1.75
25.0	1.38
38.0	1.25
50.0	1.19
75.0	1.13
100.0	1.10
150.0 or More	1.00

#### 6.5.4.6.2 Alternative calculation method

The length of bearing factor,  $K_B$ , may be calculated as follows:

$$K_B = (L_b + 9.525) / L_b \text{ for } L_b < 150 \text{ mm}$$

where:

$L_b$  = bearing length measured parallel to grain, mm

### 6.5.5 Tensile resistance parallel to grain

#### 6.5.5.1 Factored tensile resistance parallel to grain

The factored tensile resistance,  $T_r$ , parallel to grain shall be calculated as follows:

$$T_r = \phi F_t A_n K_{Zt} K_F$$

where:

$$\phi = 0.9$$

$$F_t = f_t(K_D K_{HT} K_{St} K_T)$$

$f_t$  = specified tensile strength parallel to grain, MPa  
(Tables 6.4 and 6.5 or Clause 16.3 of CSA O86-19)

$A_n$  = net area of cross-section, mm<sup>2</sup>

$K_{zt}$  = size factor in tension (Clause 6.4.4.6)

$K_F$  = flat roof factor (Clause 6.4.4.7)

**Note:** when calculating the net area cross-section of structural composite lumber members, the effective width of the board shall be further reduced by 5 mm when metal truss plates with tooth lengths greater than 9.5 mm are pressed into the member.

### 6.5.5.2 Slenderness ratio for members in tension

The slenderness ratio,  $C_c$ , of a simple tension member shall be limited to 80.  $K_e$  for a tension member shall be taken as 0.8 (see Clauses 6.5.3.1 and 6.5.3.2).

### 6.5.6 Stress index due to bending

Members subject to factored bending moment,  $M_f$ , shall be designed such that:

$$\frac{M_f}{M_r} \leq 1.0$$

### 6.5.7 Stress index due to shear

Members subject to factored shear load,  $V_f$ , shall be designed such that:

$$\frac{V_f}{V_r} \leq 1.0$$

### 6.5.8 Stress index due to compression parallel to grain

Members subject to factored compressive axial load,  $P_f$ , shall be designed such that:

$$\frac{P_f}{P_r} \leq 1.0$$

### 6.5.9 Stress index due to compression perpendicular to grain

Members subject to factored compressive bearing load,  $Q_f$ , shall be designed such that:

$$\frac{Q_f}{Q_r} \leq 1.0 \quad \text{and} \quad \frac{Q_f}{Q'_r} \leq 1.0$$

### 6.5.10 Stress index due to tension parallel to grain

Members subject to factored tensile axial load,  $T_f$ , shall be designed such that:

$$\frac{T_f}{T_r} \leq 1.0$$

### 6.5.11 Combined stress index due to tension and bending

Members subject to both bending and axial tension shall be designed such that:

$$\frac{T_f}{T_r} + \frac{M_f}{M_r} \leq 1.0$$

## 6.5.12 Combined stress index due to compression parallel to grain and bending

### 6.5.12.1 General

Except as permitted in Clause 6.5.12.2, members subject to both bending and axial compression shall be designed such that:

$$\left(\frac{P_f}{P_r}\right)^2 + \frac{M_f}{M_r} \left(\frac{1}{1 - P_f/P_E}\right) \leq 1.0$$

where:

$P_f$  = factored compressive force parallel to grain

$P_r$  = factored compressive resistance parallel to grain (Clause 6.5.3)

$M_f$  = factored bending moment

$M_r$  = factored bending moment resistance (Clause 6.5.1)

$P_E$  = Euler buckling load in the plane of the applied moment

$$= \pi^2 E_{05} K_{SE} K_T I / L_e^2$$

where:

$E_{05}$  = modulus of elasticity for design compression members, MPa

$I$  = moment of inertia in the plane of the applied moment, mm<sup>4</sup>

$L_e$  = effective length, mm (Clause 6.5.3.1)

### 6.5.12.2 Modified formula per Clause 6.5.12 CSA O86-19

Truss chord or web members subject to both bending and axial compression may be calculated in accordance with this section, provided:

- (1) the members form part of a fully triangulated, metal plate connected truss; and;
- (2) the spacing of the truss does not exceed 610 mm or the truss does not support more than 610 mm of uniform loading; and;
- (3) clear spans between bearings does not exceed 12.2 m and, the design span or overall length of the truss, not including overhangs, does not exceed 18.3 m, and with no single cantilever length exceeding 25% of the adjacent clear span, and;
- (4) the top chord slope is not less than 1/6, which is meant to exclude flat roof trusses, but not flat top trusses forming part of hip roof systems where the flat top portion does not exceed 50% of the overall length of the truss.
- (5) the member is not structural composite lumber.
- (6) the member is No.2 or better when graded in accordance with NLGA SPS 1.

**Note:** This Clause is not for use with girder, bow string, semi-circular, attic, flat roof trusses or floor trusses.

#### 6.5.12.2.1 Resistance to combined bending and axial load

Members subject to both bending and axial compression shall be so proportioned that:

$$\left(\frac{P_f}{P_r}\right)^2 + \frac{M_f}{K_M M_r} \leq 1.0$$

#### 6.5.12.2.2 Bending capacity modification factor, $K_M$

The bending capacity modification factor,  $K_M$ , shall be determined as shown in the following:

- (1) Compression chord members continuous over one or more panel points, and where;

$$1.0 < \frac{M_1}{M_2} \leq 3.0$$



$$K_M = \left[ 1.31 + 0.12 \left\{ \frac{M_1}{M_2} \right\} \right] \left\{ \frac{L_p}{d} \right\}^{-1/6} \leq 1.3$$

(2) Compression chord members continuous over one or more panel points, and where;

$$-1.0 \leq \frac{M_1}{M_2} \leq 1.0$$

$$K_M = \left[ 2.20 - 0.53 \left\{ \frac{M_1}{M_2} \right\} - 0.64 \left\{ \frac{M_1}{M_2} \right\}^2 + 0.41 \left\{ \frac{M_1}{M_2} \right\}^3 \right] \left\{ \frac{L_p}{d} \right\}^{-1/6} \leq 1.3$$

(3) All other compression chord members

$$K_M = 1.67 \left\{ \frac{L_p}{d} \right\}^{-1/6} \leq 1.3$$

where:

$L_p$  = actual length of the member between adjacent analogue panel points, mm

$d$  = depth of the member between adjacent analogue panel points, mm

\* $M_1$  = maximum bending moment between analogue panel points, N-mm

$M_2$  = maximum of the two panel point bending moments, N-mm

**Note:** The sign of the bending moment,  $M_1$  and  $M_2$  are retained in determining  $K_M$ . The factored bending moment,  $M_r$ , used in Clause 6.5.12.2.1 is the larger of the absolute value of  $M_1$  and  $M_2$ .

\* Maximum of bending moment at points along a panel where the slope of the moment curve changes sign. Where there are no such points along the panel,  $M_1$  shall take the value of the bending moment at mid panel.

## 6.6 Serviceability limit states

### 6.6.1 General

The design for serviceability limit states shall include:

- (1) Establishing the value of the effect of the specified loads individually and with the load combinations specified in Clause 5.1.4.2.
- (2) Confirming by rational means that for each load effect, the structural effect falls within the limits specified in the appropriate clauses of this standard.

### 6.6.2 Serviceability requirements

For serviceability calculations, the following shall apply:

- (1) The modulus of elasticity for stiffness calculations,  $E_s$ , shall be taken as:

$$E_s = E(K_{SE}K_T)$$

where:

$E$  = specified modulus of elasticity, MPa

(Tables 6.4 and 6.5 or Clause 16.3 of CSA O86-19)

$K_{SE}$  = service condition factor (Clause 6.4.4.3)

$K_T$  = treatment factor (Clause 6.4.4.4)

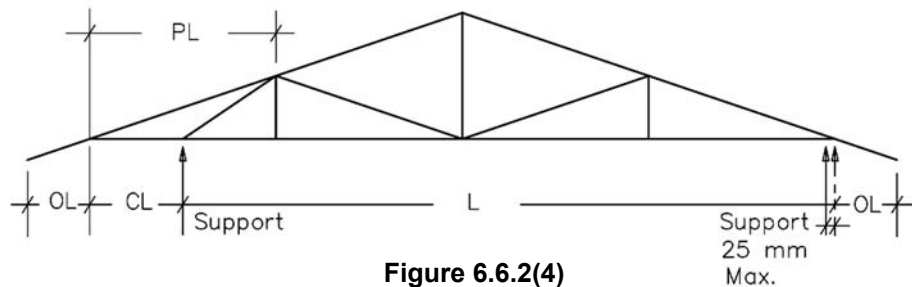
- (2) Joint and member deflections shall be determined using the methods presented in Clause 6.1 using the loadings described in Clause 5.

- (3) Maximum vertical truss deflection shall be the largest of deflections calculated at any panel point, or within any bottom chord panel. Top chord members shall be checked for their vertical panel deflections relative to their end points.
- (4) Maximum truss deflection and loadings to be considered in computing these deflections shall be as shown in Table 6.6.2. The lengths to be used in the limit ratios are shown in Figure 6.6.2(4).

**Table 6.6.2**  
**Truss deflection limits**

Deflection Location	Application			
	Roof			Floor
	Part 9	Part 4	Farm	
	Loading Used			
	1.33SL+0.5LL+DL	VL+DL	(SL+LL+WL)+DL	VL+DL
	Allowable Deflection Limits – Vertical			
Top chord panel <sup>(4)</sup>	PL/180	PL/180	PL/180	PL/180
Bottom chord panel <sup>(4)</sup>	PL/240	PL/360	PL/240	PL/360
Cantilever	CL/120	CL/120	CL/120	CL/120
Overhang	OL/120	OL/120	OL/120	N/A
Bottom chord truss joint or panel	See Below	L/180 L/360 (DL)	L/180 L/360 (DL)	L/180 L/360 (DL)
(a) Plaster/Gypsum ceiling	L/360	L/360 (VL)	L/360 (LL) <sup>(3)</sup>	L/360 (VL)
(b) Other ceiling	L/240	L/240 (VL)	L/240 (LL) <sup>(3)</sup>	L/360 (VL)
(c) No ceiling	L/180	L/240 (VL)	L/240 (LL) <sup>(3)</sup>	L/360 (VL)
	Allowable Deflection Limit – Horizontal			
At Roller Support	25 mm	25 mm	25 mm	25 mm

- (1) *SL* refers to Snow Load contribution. *LL* refers to Occupancy Load contribution. *WL* refers to Wind Load contribution. *DL* refers to Dead Load contribution.
- (2) *VL* refers to variable load combinations of *SL*, *LL* and *WL* computed in accordance with Table 5.1.4.2 – Load Combinations for Serviceability Limit States.
- (3) *(SL+LL+WL)* were considered as Live Load (*LL*) in NBC 1995. See TPIC 1996 for serviceability load combinations for Farm designs.
- (4) Top and bottom chord panel deflection is local deflection measured relative to panel ends



**Figure 6.6.2(4)**  
**Truss deflection lengths**

### 6.6.3 Permanent deformation

Structural members that support long-term loads shall be designed to limit permanent deformation. In the absence of a more accurate evaluation of acceptable deflection limits, an upper limit of 1/360 of the span shall be imposed on the elastic deflection due to long-term service load combinations.

### 6.6.4 Ponding

The roof surface shall be provided with sufficient slope to allow drainage to prevent accumulation of rain water.

### 6.6.5 Top chord bearing trusses with lumber-on-flat

For lumber-on-flat top chord bearing trusses where the gap dimension "A", as specified in Appendix E, is greater than 13 mm, the calculated joint and member deflections shall be determined using the methods presented in Clause 6.1 using the loadings described in Clause 5 multiplied by:

- (1) 1.125 for one (1) top chord bearing joint
- (2) 1.25 for two (2) top chord bearing joints

## 6.7 Special design considerations

### 6.7.1 Overhangs

Top chord overhangs for all categories of trusses shall be treated as simple overhangs, with no consideration of any support provided by the soffit return, except in cases where the truss designer is able to ensure that such consideration is provided for in the design and construction of the building.

### 6.7.2 Splices

Splices in the top or bottom chord of a truss can be described as either inner panel or panel point splices.

#### 6.7.2.1 Inner panel splices

Inner panel splices are splices located between panel points and are subject to the following:

- (1) Inner panel splices may be designed as pinned or as moment splices per Clause 7.5.8.
- (2) Pinned splices shall not be located in panels containing a heel joint, or panels containing a top chord bearing joint or a bottom chord extended bearing joint.
- (3) Moment splices may occur anywhere in the panel with the following exceptions:
  - (a) In the heel panel, a moment splice shall not be located closer than 610 mm from the end of the scarf cut.
  - (b) In the panel containing a top chord bearing joint or a bottom chord extended bearing joint, a moment splice shall not be located closer than 610 mm from the panel point nearest the bearing.
- (4) Two moment splices in a single panel shall not occur in the top chord. Two splices in the bottom chord is permitted provided they are not located closer than 610 mm from any panel point splice.

#### 6.7.2.2 Panel point splices

Panel point splices are splices that occur at panel points and are subject to the following:

- (1) Panel point splices shall be designed as pinned splices
- (2) Panel point splices may occur at any panel point with the exception of the heel joint, top chord bearing joint or bottom chord extended bearing joint

#### 6.7.2.3 Interference of splices

Splices shall not be located such that the plating or blocking interferes with other splice or non splice plating.

### 6.7.3 Short cantilevers and heel cuts

Short cantilevers and high heel cuts shall be designed in accordance with the procedures presented in Appendix B.

## 6.7.4 Girder trusses (single and multi-ply)

### 6.7.4.1 Girder type heels

#### 6.7.4.1.1 Scarf cuts

Girder type heels are created by cutting the top chord onto a scarfed bottom chord. For scarf cuts, the resulting section of bottom chord directly over the inside face of the bearing shall not be less than the greater of:

- (1) 50% of the original bottom chord section or 100 mm for sawn lumber.
- (2) 60% of the original bottom chord section or 100 mm for structural composite lumber.

#### 6.7.4.1.2 Design procedures

For sawn lumber, girder type heel design shall be in accordance with Appendix F.

**Note:** For structural composite lumber, failure modes for this heel type can vary by SCL product and thus girder type heel design procedures should be provided by the SCL manufacturer.

### 6.7.4.2 Ply-to-ply laminating of multi-ply girders trusses

Ply-to-ply laminating of multi-ply girder trusses shall conform to the following:

- (1) The girder truss shall be limited to a maximum of five (5) plies when carrying load that is not applied evenly to each ply. Laminating using nails may be performed in accordance with Appendix C.
- (2) The girder truss shall be limited to a maximum of ten (10) plies when carrying load that is evenly applied to all plies. Laminating using nails may be performed using the minimum number of rows shown in Table C.1.1 and a spacing of 305 mm o/c.
- (3) Girder trusses meeting the requirements of Clause 6.7.4.2(1), with four (4) or more plies, shall be fastened together with a ½" diameter ASTM A307 Grade A bolt (including nuts and standard cut washers) between panel points on both the top and bottom chords when laminating using nails.

## 6.7.5 Truss bracing

### 6.7.5.1 General

- (1) For instructions on installation of temporary and permanent truss bracing, refer to SBCA publication "BCSI Canada – Guide to Good Practice for Handling, Installing, Restraining & Bracing of Metal Plate Connected Wood Trusses."
- (2) Truss bracing location, as required in the design of the truss component, shall be specified by the truss designer/engineer.
- (3) For Part 9 trusses, minimum fastening of braces shall be as per article 9.23.14.11 of NBC 2020.

19 x 89 braces 2 – 63 mm common wire nails

38 x 89 braces 2 – 76 mm common wire nails

- (4) An alternate method for bracing compression webs and long tension webs is by applying a member parallel to the web to form a T-section. See Table D.1., Appendix D.

### 6.7.5.2 Lateral brace force for wood truss compression webs

The lateral force in a brace used to resist out-of-plane deflection in axial compression web members in light metal plate connected wood trusses shall be 1.25% of the axial compressive force in the member. This value shall apply equally to both single-braced and double-braced webs.

**Note:** in repetitive member systems the lateral brace force is cumulative.

## 6.7.6 Top chord bearing guidelines

Note: See Appendix E

### 6.7.6.1 Lumber-on-edge

#### 6.7.6.1.1 General

For lumber-on-edge top chord bearing trusses the recommended maximum factored reactions for S-P-F, D.Fir.L and structural composite lumber chords are as shown in Table E.1 for various truss configurations. The recommended maximum gaps and minimum chord coverage must be observed when using these values. Reaction limits are based on gross reaction and load duration factor for standard term loading. Values shall be adjusted downward for permanent loading and upward for short term loading using appropriate duration of load factors for plating.

#### 6.7.6.1.2 Plating requirements for bearing blocks

Where bearing blocks are used, as shown in Detail 2 or Detail 7 of Figure E.1, the following shall apply:

- (1) Bearing blocks that are equal to or longer than 610 mm shall be plated to the adjacent vertical web within 150 mm of the bottom end of the bearing block, at intermediate intervals not exceeding 1.2 m and at each location where a continuous lateral brace is attached to that adjacent web.
- (2) Truss plates at locations where a continuous lateral brace is attached to the adjacent web shall have a dimension along the joint (between the bearing block and the adjacent vertical web) not less than 76 mm and not less than a dimension equal to the force in the continuous lateral brace divided by 0.013 kN/mm/pair.
- (3) The truss plate closest to the bearing shall have a bite onto the bearing block no less than 60% of the width of the bearing block.

### 6.7.6.2 Lumber-on-flat

For lumber-on-flat top chord bearing trusses, the recommended maximum factored reactions for S-P-F and D.Fir.L chords are as shown in Table E.2 for the various truss configurations. The recommended maximum gaps and minimum chord bites also shown must be observed when using these values. Reaction limits are based on gross reaction and load duration factor for standard term loading. Values shall be adjusted downward for permanent loading and upward for short term loading using appropriate duration of load factors for plating.

Note: See Clause 6.6.5 for additional serviceability requirements

## 6.7.7 Long-span trusses

The following provisions apply to trusses with a clear span between bearings greater than 24.4 m.

### 6.7.7.1 General

- (1) Trusses shall only be used in dry service conditions.
- (2) Trusses shall be manufactured using lumber having a moisture content no greater than 19% at the time of fabrication.
- (3) The maximum JSI for lateral resistance of connector plates shall be 0.80
- (4) The height of the bottom chord of a truss at the interior side of bearing at a heel joint shall be no less than 75% of the chord depth.

### 6.7.7.2 Trusses with a clear span greater than 30.5 m

Where trusses have a clear span between bearings greater than 30.5 m the additional provisions shall apply:

- (1) Trusses shall be designed as a minimum of two plies.
- (2) Where ply-to-ply laminating is performed with nails the spacing shall not exceed 228 mm in compression members.
- (3) The maximum CSI for lumber shall be 0.90.

## 6.7.8 Attic frames

### 6.7.8.1 General

Non-triangulated attic frames shall be designed in accordance with Part 4 of NBC 2020.

### 6.7.8.2 Floor vibration of attic frames

The attic room width shall not exceed 22 times the depth of the attic floor member unless a vibration analysis, using a recognized procedure, permits otherwise (see Clause 5.2.2.3).

## 7. Joint Design Procedures

### 7.1 General

The design requirements for truss plate joints, utilizing light gauge metal plates, shall be in accordance with Clause 12.8 of CSA O86-19.

#### 7.1.1 Exceptions

The procedures in Clause 7 do not apply to the following:

- (1) truss plates under corrosive conditions
- (2) galvanized truss plates used in lumber that has been treated with fire retardant and is used in wet service conditions or in locations prone to condensation
- (3) truss plates with teeth pressed into the narrow edge of structural composite lumber unless permitted by the manufacturer and approval is documented in their product evaluation report

**NOTE:** For metal connector plates used in environmental conditions that fall within the scope of (1) & (2) above, refer to TPIC Technical Bulletin #4 – Design for Corrosive Environments

#### 7.1.2 Design assumptions

Design criteria for truss plates are based on the following conditions:

- (1) the plate is prevented from deforming during installation;
- (2) the teeth are normal to the surface of the lumber;
- (3) the tooth penetration in joints is not less than that used in the tests to determine the resistance values;
- (4) the lumber beneath the plate complies with Appendix G

#### 7.1.3 Minimum member thickness

Thickness of members used in joints shall not be less than twice the tooth penetration.

#### 7.1.4 Placement of plates in joints

Joint design shall be based on tight fitted joints with truss plates placed on opposing faces in such a way that at each joint the plates on opposing faces are identical and are placed directly opposite each other.

#### 7.1.5 Primary axis of truss plates

The lateral resistance value used to determine necessary plate area for any member shall be the appropriate value considering direction of load relative to grain and direction of load relative to the primary axis of the plate (see Figure 7.3.3.3). The resistance value is determined using the test values in conjunction with the formulae contained in Clauses 7.3 and 7.4.

#### 7.1.6 Surface area

The unit values of lateral resistance of teeth shall be expressed as per tooth, per rosette, or per net area, whichever is appropriate or preferred. The design shall be based on net area method using test values or on gross area method using 80 percent of the test values and with areas defined as follows:

- (1) the gross area is defined as the total area of member covered by a truss plate.
- (2) the net area is defined as the total area of a member covered by a truss plate less the area within a given distance from the edge or end of member. For net area calculation, the minimum end distance

measured parallel to grain, shall be the greater of 12 mm or 1/2 the length of tooth; the minimum edge distance measured perpendicular to grain, shall be the greater of 6 mm or 1/4 the length of the tooth.

- (3) Any joint in a truss may be designed by either net or gross area method of joint design but not a combination of both within same joint.
- (4) For heel joints designed in accordance with Clause 7.5.7, the gross area may be used for net area method calculations.

### 7.1.7 Minimum bite for chords and webs

Except as provided in Clause 7.1.7.1, at all joints, the connector plates are to be sized such that the minimum bites into all chords and webs are as given in Table 7.1.7.

#### 7.1.7.1 Exceptions

An exception to the minimums listed in Table 7.1.7 is the case of a single web to through-chord joint for  $0 < L < 12.5$  m and for lumber sizes of 38 x 64 to 38 x 140 where 25 mm wide, minimum 76 mm long plates may be used.

**Table 7.1.7**  
Minimum bite for chords and webs, mm

Lumber Size	Truss Length L, m			
	$0 < L \leq 12.5$	$12.5 < L \leq 18.3$	$18.3 < L \leq 24.4$	$L > 24.4$
38x64	38	45	51	57
38x89	38	45	51	57
38x114	38	45	51	57
38x140	38	51	57	64
38x184	51	57	64	76
38x235	64	70	76	83
38x286	76	76	83	89

**Note:** (1) Plates must be sized so that the min. bite into chords is as shown above:

- (a) parallel to chord direction
- (b) perpendicular to chord direction

(2) Plates must be sized so that the min. bite into webs is as shown above:

- (a) parallel to chord direction
- (b) perpendicular to chord direction
- (c) along the centreline of the web

## 7.2 Strength resistance of truss plates

### 7.2.1 General

The metal connector plate design values shall be obtained from tests carried out in accordance with CSA S347-14 "Method of Test for Evaluation of Truss Plates used in Lumber Joints," latest edition.

### 7.2.2 Ultimate lateral resistance of teeth

The ultimate lateral resistance values,  $p_u$ ,  $q_u$ ,  $p'_u$  and  $q'_u$ , shall be calculated as follows:

$$n_u = 0.8 R_c B K_{pu} K_{mu}$$

where

$n_u$  = ultimate lateral resistance values  $p_u, q_u, p'_u, q'_u$

$R_c$  = the lesser of the following:

(a)  $R_u (1 - 2.104 CV)$

(b)  $0.753 R_u$

$R_u$  = average ultimate lateral resistance of the test data

$B = 1.44 - 2.18 CV$ , but not greater than 1.1

$CV$  = coefficient of variation of the test data

$K_{pu}$  = roller press modification factor for ultimate strength, determined in accordance with CSA S347

$K_{mu}$  = moisture response factor for ultimate strength

= 0.83 for sawn lumber to sawn lumber connections

= determined in accordance with CSA S347 for structural composite lumber to structural composite lumber connections, and sawn lumber to structural composite lumber connections.

**Note:** where the moisture response factor for structural composite lumber to sawn lumber is less than 0.83, two values of  $n_u$  will be calculated for sawn lumber connections, one value of  $n_u$  for sawn lumber to sawn lumber and one value of  $n_u$  for sawn lumber to structural composite lumber connections.

### 7.2.3 Tensile resistance

The tensile resistance of the plate,  $t_p$ , shall be determined parallel and perpendicular to the direction of the applied load and calculated as follows:

$$t_p = t_{uL}CF$$

where:

$t_{uL}$  = characteristic tensile strength from CSA S347, N/mm

$CF$  = correction factor for strength of plate material from CSA S347

### 7.2.4 Shear resistance

The shear resistance of the plate,  $v_p$ , shall be determined for specified angles of plate axis to load direction and calculated as follows:

$$v_p = v_{uL}CF$$

where:

$v_{uL}$  = characteristic shear strength from CSA S347, N/mm

$CF$  = correction factor for strength of plate material from CSA S347

For all other angles, shear resistance shall be determined by linear interpolation.

### 7.2.5 Lateral slip resistance

The resistance values,  $p_s, q_s, p'_s$  and  $q'_s$  shall be calculated as follows:

$$n_s = (R_s / 1.2) K_{ps} K_{ms}$$

where:

$n_s$  = lateral slip resistance values  $p_s, q_s, p'_s$  and  $q'_s$

$R_s$  = average lateral resistance at 0.8 mm wood-to-wood slip, determined in accordance with CSA S347

$K_{ps}$  = roller press modification factor for slip, determined in accordance with CSA S347

$K_{ms}$  = moisture response factor for slip

= 0.83 for sawn lumber to sawn lumber connections

= determined in accordance with CSA S347 for structural composite lumber to structural composite lumber connections, and sawn lumber to structural composite lumber connections.

**Note:** where the moisture response factor for structural composite lumber to sawn lumber is less than 0.83, two values of  $n_s$  will be calculated for sawn lumber connections, one for sawn lumber to sawn lumber, and one for sawn lumber to structural composite lumber



## 7.3 Ultimate limit states

### 7.3.1 General

Truss plate joints shall be designed such that for the ultimate limit state, the effect of the factored load is less than or equal to;

- (1) the factored ultimate lateral resistance of the teeth;
- (2) the factored tensile resistance of the plates; and
- (3) the factored shear resistance of the plates;

### 7.3.2 Modification factors

#### 7.3.2.1 Load duration factor, $K_D$

The load duration factor,  $K_D$ , for truss plates shall be as given in Clause 6.4.4.2.

#### 7.3.2.2 Service condition factor, $K_{SF}$

The service condition factor,  $K_{SF}$ , for truss plates is given in Table 7.3.2.2.

**Table 7.3.2.2**  
Service condition factor,  $K_{SF}$

Lumber Condition at Time of Manufacture			
Dry ( $\leq 19\%$ )		Wet ( $> 19\%$ )	
Lumber Condition in Service			
Dry	Wet	Dry	Wet
1.00	0.67	0.80	0.67

**Note:** the standard G90 galvanized coating used on truss plates may not be suitable for trusses designed for use in wet service conditions. Contact the truss plate manufacturer for additional information.

#### 7.3.2.3 Treatment factor, $K_T$

For connections containing wood-based members treated with fire-retardant or other strength-reducing chemicals, strength capacities of connections shall be based on the documented results of tests that shall take into account the effect of time, temperature, and moisture content. Test procedures shall meet the requirements of Clause 4.3.2 from CSA O86-14.

**Note:** The effects of fire-retardant treatments can vary depending on manufacturing materials and processes. See the commentary in the CWC Wood Design Manual.

#### 7.3.2.4 Flat roof factor, $K_F$

Roof trusses meeting the housing and small building requirements of Part 9 of the NBC 2020 and carrying flat roof (where roof portion with slope  $< 1:6$  exceeds 50% of building width) shall be designed with a reduced factored resistance strength of plate by applying a flat roof factor  $K_F = 0.75$ . For all other cases  $K_F = 1.0$ .

## 7.3.3 Factored resistance of truss plates

### 7.3.3.1 General

For the ultimate limit state the factored resistances of truss plates shall be determined in accordance with this clause.

### 7.3.3.2 Factored ultimate lateral resistance of teeth, $N_r$

The factored ultimate lateral resistance of the teeth,  $N_r$ , shall be expressed in terms of the surface area of the plates and shall be calculated as follows:

$$N_r = \phi N_u J_H K_F$$

where:

$$\phi = 0.9$$

$$N_u = n_u (K_D K_{SF} K_T)$$

$K_D$  = load duration factor (Clause 6.4.4.2)

$K_{SF}$  = service condition factor for truss plates (Clause 7.3.2.2)

$K_T$  = treatment factor (Clause 7.3.2.3)

$n_u$  = ultimate lateral resistance of the teeth, MPa (Clause 7.3.3.3)

$J_H$  = moment factor for heel connection (Clause 7.5.7)

$K_F$  = flat roof factor (Clause 7.3.2.4)

### 7.3.3.3 Ultimate lateral resistance of the teeth, $n_u$

The ultimate lateral resistance of the teeth,  $n_u$ , shall be calculated as follows:

(1) For loads parallel to the primary axis of the plate:

$$n_u = \frac{p_u q_u}{p_u \sin^2 \theta + q_u \cos^2 \theta}$$

(2) For loads perpendicular to the primary axis of the plate

$$n'_u = \frac{p'_u q'_u}{p'_u \sin^2 \theta + q'_u \cos^2 \theta}$$

where:

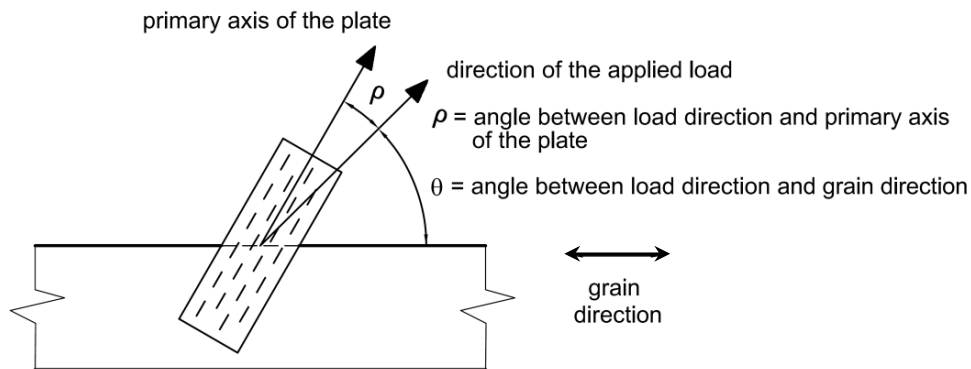
$p_u, q_u, p'_u, q'_u$  are the ultimate lateral resistances obtained in accordance with Clause 7.2.2 used with the following values of  $\theta$  and  $\rho$  as defined in Figure 7.3.3.3:

$p_u$ :  $\theta=0^\circ, \rho=0^\circ$

$q_u$ :  $\theta=90^\circ, \rho=0^\circ$

$p'_u$ :  $\theta=0^\circ, \rho=90^\circ$

$q'_u$ :  $\theta=90^\circ, \rho=90^\circ$



**Figure 7.3.3.3**  
Truss plate, load and grain orientation

- (3) When the primary axis of the plate is oriented at an angle other than parallel or perpendicular to the direction of the load, the resistance value shall be determined by linear interpolation between the values  $n_U$  and  $n'_U$ .

#### 7.3.3.4 Factored tensile resistance of the plate, $T_r$

The factored tensile resistance of the plate,  $T_r$ , shall be expressed in terms of the dimension of the plate measured perpendicular to the line of action of the applied forces and shall be calculated as follows:

$$T_r = \phi t_p K_F$$

where:

$$\phi = 0.6$$

$t_p$  = tensile resistance of the plate (Clause 7.2.3)

$K_F$  = flat roof factor (Clause 7.3.2.4)

**Note:**  $t_p$  is determined for both parallel and perpendicular to the direction of the plate primary axis in accordance with 7.2.3. For all other angles, tensile resistances shall be determined by linear interpolation.

#### 7.3.3.5 Factored shear resistance of the plate, $V_r$

The factored shear resistance of the plate,  $V_r$ , shall be expressed in terms of the dimension of the plate measured along the line of action of the shear forces and shall be calculated as follows:

$$V_r = \phi v_p K_F$$

where:

$$\phi = 0.6$$

$v_p$  = shear resistance of the plate (Clause 7.2.4)

$K_F$  = flat roof factor (Clause 7.3.2.4)

**Note:**  $v_p$  is determined for specified angles of the plate primary axis to load direction in accordance with Clause 7.2.4. For all other angles, shear resistances shall be determined by linear interpolation.

### 7.4 Serviceability limit states

#### 7.4.1 General

Truss plate joints shall be designed such that for the serviceability limit state the effect of specified loads is less than or equal to the lateral slip resistance of the teeth.

#### 7.4.2 Lateral slip resistance

##### 7.4.2.1 Adjusted lateral slip resistance of the teeth

For the serviceability limit state, the adjusted lateral slip resistance of the teeth,  $N_{rs}$ , shall be calculated as follows:

$$N_{rs} = n_s K_{SF}$$

where

$n_s$  = lateral slip resistance of the teeth (Clause 7.4.2.2)

$K_{SF}$  = service condition factor for truss plates (Clause 7.3.2.2)

##### 7.4.2.2 Lateral slip resistance of the teeth

The lateral slip resistance of the teeth,  $n_s$ , shall be calculated as follows:

- (1) For loads parallel to the primary axis of the plate

$$n_s = \frac{p_s q_s}{p_s \sin^2 \theta + q_s \cos^2 \theta}$$

- (2) For loads perpendicular to the primary axis of the plate

$$n'_s = \frac{p'_s q'_s}{p'_s \sin^2 \theta + q'_s \cos^2 \theta}$$

where:

$p_s, q_s, p'_s, q'_s$  are the lateral slip resistances obtained in accordance with Clause 7.2.5 used with the following values of  $\theta$  and  $\rho$  as defined in Figure 7.3.3.3:

$p_s$ :  $\theta=0^\circ, \rho=0^\circ$

$q_s$ :  $\theta=90^\circ, \rho=0^\circ$

$p'_s$ :  $\theta=0^\circ, \rho=90^\circ$

$q'_s$ :  $\theta=90^\circ, \rho=90^\circ$

- (3) When the primary axis of the plate is oriented at an angle other than parallel or perpendicular to the direction of the load, the resistance value shall be determined by linear interpolation between the values  $n_s$  and  $n'_s$ .

## 7.5 Member joint connections

### 7.5.1 Connection of tension members

- (1) The factored lateral resistance,  $N_r$ , in each tension member must be a minimum of 100% of the factored axial load in the member.
- (2) There must be sufficient factored tensile resistance,  $T_r$ , in the connector plates to transmit the full factored axial load in each tension member, considering the appropriate planes of action.

### 7.5.2 Connection of compression members

- (1) Metal connector plates resisting factored compressive axial loads shall be sized to provide factored lateral resistance,  $N_r$ , equal to the vectorial sum of no less than 50% of the component factored loads normal to the wood member interface, and 100% of the component factored loads parallel to the wood member interface.
- (2) Truss plates shall not be considered to transfer compression loads at joints.

**Note:** See Clause 7.5.8.3 for additional requirements applicable to compression splices

### 7.5.3 Connection of members for shear

- (1) There must be sufficient factored lateral resistance of the teeth,  $N_r$ , in webs and chords to transmit the factored shear loads at a joint.
- (2) There must be sufficient factored shear resistance,  $V_r$ , in the truss plates to transmit the factored shear loads at a joint.

### 7.5.4 Combined shear-tension resistance

The combined factored shear and tension resistance,  $C_{rST}$ , of the metal connector plate in the contact area of webs and chords, shall be determined as follows:

$$C_{rST} = (ST_{rL1} L_1 + ST_{rL2} L_2) \leq T_{rw}$$

where:

$L_1$  = length of effective steel at the horizontal edge of the member under consideration (Figure 7.5.4)

$L_2$  = length of effective steel at the vertical edge of the member under consideration (Figure 7.5.4)

$ST_{rL1}$  = combined factored shear/tension resistance of the pair of metal connector plates through the line of contact  $L_1$ .

$$= V_{rL1} + \left(\frac{\theta_1}{90}\right)(T_{rL1} - V_{rL1})$$

$ST_{rL2}$  = combined factored shear/tension resistance of the pair of metal connector plates through line of contact  $L_2$ .

$$= T_{rL2} + \left(\frac{\theta_1}{90}\right)(V_{rL2} - T_{rL2})$$

$V_{rL1}$  = factored shear resistance parallel to the line of action, L1

$V_{rL2}$  = factored shear resistance parallel to the line of action, L2

$T_{rL1}$  = factored tensile resistance perpendicular to the line of action, L1

$T_{rL2}$  = factored tensile resistance perpendicular to the line of action, L2

$T_{fw}$  = factored tensile force in web (Figure 7.5.4)

**Note:** Where the truss plate extends significantly past any chord and/or web member, additional blocking is recommended.

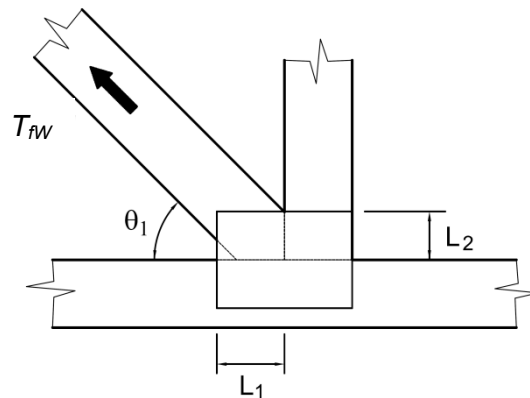


Figure 7.5.4 - Shear-tension lengths and angles

### 7.5.5 Net section lumber check, $h'$

At all joints, members shall have metal connector plates sized and/or positioned so that the stress index of the member is not exceeded on the reduced net section resulting from the coverage of the plate,  $h'$ , due to the following:

- (1) compression parallel to grain of the member at any joint without wood-to-wood bearing in the direction of the axial force.
- (2) tension parallel to grain.

**Note:** See Figure 7.5.5

### 7.5.6 Tension perpendicular-to-grain considerations

Any joint which carries a factored concentrated load that is perpendicular to the chord or has a component that is perpendicular to the chord and/or has a shear component that is perpendicular to the chord and exceeds 2.5 kN must be reinforced for tension perpendicular-to-grain with a minimum chord bite as follows:

$$\text{Min. Bite (mm)} = \frac{P - 2.500}{0.041} \text{ For S-P-F and SCL}$$

$$\text{Min. Bite (mm)} = \frac{P - 2.500}{0.055} \text{ For D.Fir-L}$$

where:

$P$  = Factored concentrated load, kN

**Note:** The calculated minimum bite requirement need not exceed 3/4 of the depth of the lumber.

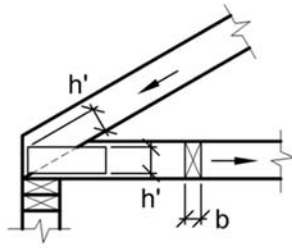


Figure 7.5.5a

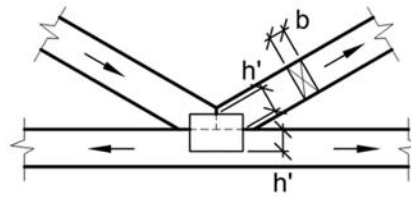


Figure 7.5.5b

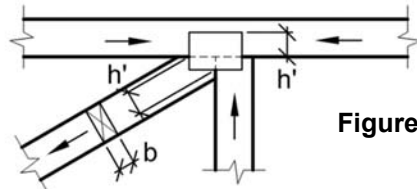


Figure 7.5.5c

Figure 7.5.5  
Typical  $h'$  dimensions

### 7.5.7 Heel Joint Considerations

- (1) To allow for moment effects at the heel joint of pitched trusses, the heel joint moment factor,  $J_H$ , shall be as given in Table 7.5.7.

Table 7.5.7  
Heel Joint Moment Factors,  $J_H$

Slope of top chord	$J_H$
Under 1/4 slope	0.85
1/4 to less than 1/3 slope	0.80
1/3 to less than 1/2.4 slope	0.75
1/2.4 to 1/2.2 inclusive	0.70
over 1/2.2 slope	0.65

- (2) In lieu of the values from the table above, the following formula can be used in determining the Heel Joint Moment Factor:

$$J_H = 0.85 - 0.05 (12 \tan \theta - 2.0)$$

$$0.65 \leq J_H \leq 0.85$$

where:

$\theta$  = the angle between the top and bottom chord

- (3) Where the vertical reaction results in factored shear loads that exceed the factored shear resistance of the lumber, the heel joint lumber may be reinforced by additional plating. For the design of the additional plating for girder type heels, refer to Appendix F.

- (4) The heel joint of a chord extended rafter shall be plated as an ordinary heel joint with the appropriate heel joint moment factor applied. Consideration should be given to prevent splitting due to tension perpendicular-to-grain and longitudinal shear by supplementary plating on the continuous rafter.

## 7.5.8 Chord member splice considerations

### 7.5.8.1 General

For all chord splices the plate width shall be at least 65% of the width of the chord member.

### 7.5.8.2 Tension and/or moment splices

- (1) When determining the factored tensile resistance or moment resistance of the metal connector plate, the maximum effective extension of the metal connector plate for an unblocked chord splice shall be 13 mm.
- (2) In the case of blocked tension and/or moment splices, the plate effective width,  $w_{br}$ , shall be calculated as follows:

$$w_{br} = w K \geq w - X + A$$

where:

$w$  = width of steel plate perpendicular to the line of force, mm

$$K = 0.97e^{-0.001(3.937 + 0.0186(88.9-d))X}$$

where:

$d$  = depth of chord, mm.

$X$  = extension of plate beyond the wood member, mm  
(maximum allowed in this calculation is 89 mm).

$A$  = the lesser of  $X$  or 13 mm

**Note:** (1) For an unblocked tension splice with an extension of 13 mm or less,  $K = 1.0$ .

(2) In the case of a splice occurring at the panel joint, webs framing into joint shall be considered as blocking.

(3) Maximum plate width to be applied with effectiveness factor  $K$  cannot be in excess of the depth of the member,  $d$ , plus the maximum extension,  $X$ .

### 7.5.8.3 Compression splices

- (1) Compression splice plates shall be designed so that the factored lateral resistance in each member will be at least equal to 65% of the factored compressive axial load.
- (2) In plumb cut compression joints the metal connector plates resisting factored compressive axial loads shall be sized to provide factored lateral resistance, equal to the vectorial sum of no less than 65% of the component factored loads normal to the wood member interface and 100% of the component factored loads parallel to the wood member interface.

### 7.5.8.4 Moment considerations

When in line members terminate at an inner panel splice (see Clause 6.7.2) and chord moment should be considered, the splice plates shall have sufficient resistance to transfer the factored bending moment in combination with the factored axial load. The resistance shall be verified for both plate steel section per Clause 7.5.8.4.1 and plate lateral resistance per Clause 7.5.8.4.2.

**Note:** Clause 7.5.8.4 is only applicable to truss plates pressed into the wide face (depth) of the lumber.

#### 7.5.8.4.1 Design of steel section for effect of moment

The design of the steel section for the effect of moment shall conform to either Clause 7.5.8.4.1.1 or Clause 7.5.8.4.1.2 for trusses with lumber-on-edge or Clause 7.5.8.4.1.3 for trusses with lumber-on-flat.

### 7.5.8.4.1.1 Lumber-on-edge

The factored moment resistance in combination with tension or compression,  $M_{rT}$ , of a pair of connector plates at a splice joint in trusses with lumber-on-edge shall be taken as:

$$M_{rT} = 0.24 C_m K_F [ T_1 (w_{br} + y + z - d) + T_2 (4w_{br} + 2y + 4z - 3d) / 3 + C_s (d - z - y) + C_w (d - y) ] \geq 0$$

where:

$K_F$  = flat roof factor (Clause 7.3.2.4)

$$C_m = 1 - (X' / L) P_f / P_E$$

= 1.0 when CSI is determined in accordance with Clause 6.5.12.2

where:

$X'$  = twice the distance from the splice to the nearest panel point, mm

$L$  = length of the chord panel containing the splice, mm

$P_f$  = factored compressive axial load (equal to zero if the force is tension)

$P_E$  = Euler buckling load in the plane of the applied moment

$$= \pi^2 E_{05} K_{SE} K_T I / L_e^2$$

where:

$E_{05}$  = modulus of elasticity for design compression members, MPa

$I$  = moment of inertia in the plane of the applied moment, mm<sup>4</sup>

$L_e$  = effective length, mm (Clause 6.5.3.1)

$$T_1 = 2t_p F_y (w_{br} - y + z) / F_u$$

$$T_2 = t_p (1 - F_y / F_u) (w_{br} - y + z)$$

$$C_s = 0.8t_p F_y (y - z) / F_u$$

$$C_w = y b C$$

Where:

$t_p$  = tensile resistance of the plate, N/mm (Clause 7.2.3)

$w_{br}$  = effective plate width for steel section calculations, mm (Clause 7.5.8.2)

$y$  = distance from the edge of the chord to the neutral axis of wood/steel combination, mm (y can be positive or negative)

$$C = \frac{t_p \left[ \frac{F_y}{F_u} (1.8z + w_{br}) + (w_{br} + z) \right] - 1.67T_f}{bC + t_p \left( 1.8 \frac{F_y}{F_u} + 1 \right)}$$

$b$  = chord thickness, mm

$F_y$  = specified minimum yield strength of the steel, MPa

$F_u$  = specified minimum tensile strength of the steel, MPa

$C$  =  $1.4f_c(K_D K_{Hc} K_{Sc} K_T K_{Zc})$ , MPa

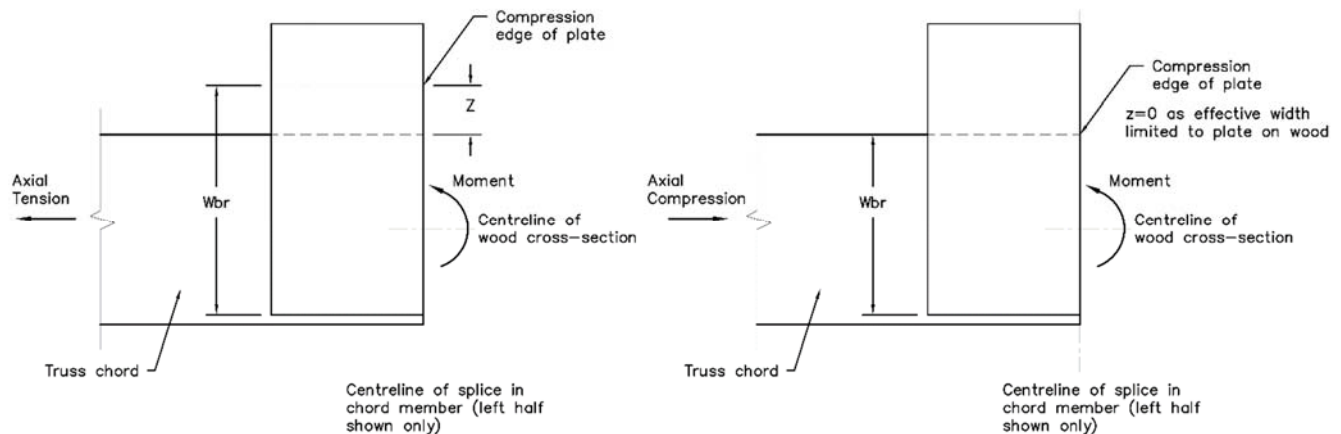
$d$  = depth of chord (smaller of the two depths for differing chord sizes), mm

$T_f$  = factored tension force in chord at the splice, N (positive if tension and negative if compression)

$z$  = distance from compression edge of lumber to compression edge of truss plate, mm

**Note:**  $z$  is positive if the compression edge of the plate is closer than the compression edge of the lumber to the centre of wood cross-section; negative if the compression edge of the lumber is closer than the compression edge of the plate to the centre of the wood cross-section. For members subject to axial tension force such that there is no compression, the compression edge is defined as that edge with the least tension. The compression edge of the plate shall be limited to the edge of  $w_{br}$ .





**Figure 7.5.8**  
Illustration of z dimension

#### 7.5.8.4.1.2 Lumber-on-edge using combined stress index

As an alternative to the design procedure in Clause 7.5.8.4.1.1 the factored moment resistance in combination with tension or compression of a pair of connector plates at a splice joint in trusses with lumber-on-edge may be designed using the following:

$$M_f / M_{rT0} + X_f / X_r \leq 1.0$$

where:

$M_f$  = factored bending moment in the chord at the splice, N·mm

$M_{rT0}$  = factored moment resistance,  $M_{rT}$ , per Clause 7.5.8.4.1.1 using  $T_f = 0$ , N·mm

$X_f$  = factored axial force in the chord, N

$X_r$  = factored resistance, N,

= factored compressive resistance parallel to grain,  $P_r$ , per Clause 6.5.3.3 using  $K_C = 1.0$  and  $K_{Zc} = 1.3$  when the factored axial force is in compression, N

= factored tensile resistance of the plates,  $T_r$ , per Clauses 7.3.3.4 and 7.5.8.2 when the factored axial force is in tension, N

#### 7.5.8.4.1.3 Lumber-on-flat

The factored moment resistance in combination with tension or compression,  $M_{rT}$ , of a pair of connector plates at a splice joint in trusses with lumber-on-flat shall be taken as:

$$M_{rT} = (T_{rp} - T_f) Y / 2$$

where:

$T_{rp}$  = factored tension resistance of the pair of plates, N, equal to the lesser of the following two values:

$$= 2 N_r A_{ef}$$

$$= 2 T_r w$$

Where:

$N_r$  = factored lateral resistance of the teeth, MPa (Clause 7.3.3.2)

$A_{ef}$  = effective plate area on one face of wood member at splice joint, mm<sup>2</sup> (Clause 7.5.8.4.2)

$T_r$  = factored tensile resistance of a single plate, N (Clause 7.3.3.4)

$w$  = width of steel plate perpendicular to the line of force, mm

$T_f$  = factored tension force in chord at splice joint ( $T_f = 0$  if in compression), N

$Y$  = moment arm between compression and tension components, mm

$$= d - \frac{(T_{rp} - T_f)}{4 b F_c}$$

where:

$d$  = depth of chord, mm

$b$  = chord thickness, mm

$F_c = f_c(K_D K_{Hc} K_{Sc} K_T K_{Zc})$ , MPa

**Note:** For lumber on flat, the depth of the chord ( $d$ ) for the above calculation is the total built-up lumber thickness (38 mm, 76 mm or 114 mm) and the chord thickness ( $b$ ) is the width of the lumber.

#### 7.5.8.4.2 Design of plate lateral resistance for effect of moment

The moment applied at the splice joint in trusses with lumber-on-edge shall not exceed the moment capacity in lateral resistance in any orientation, nor the combined capacity for moment and non-moment loads defined as follows:

$$N_{fM} \leq N_{rMIN}$$

and

$$N_{fM} + N_{fP} \leq N_{rP}$$

where:

$N_{fP}$  = factored lateral stress resultant of factored shear and factored axial loads in wood on a pair of plates, MPa, equal to the vector addition of the factored shear + factored axial loads in wood, divided by  $A_{ef}$ .

$N_{rP}$  = factored lateral resistance for a pair of plates for the orientation of  $N_{fP}$  with modification factors of Clause 7.3.2, MPa

$N_{rMIN}$  = minimum factored lateral resistance for any angle of load at the joint for a pair of plates determined from Clause 7.5.3 with modification factors of Clause 7.3.2, MPa

$N_{fM}$  = factored lateral stress due to the factored moment on a pair of plates, MPa  
 $= 4 M_f / (A_{ef} D)$

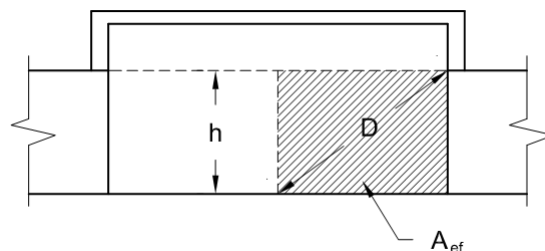
where:

$A_{ef}$  = effective plate area on one face of each wood member at the splice joint, mm<sup>2</sup> (Figure 7.5.8.4.2)

$D$  = diagonal of rectangle equivalent to  $A_{ef}$ , mm (Figure 7.5.8.4.2)  
 $= \sqrt{(A_{ef} / h)^2 + h^2}$

where:

$h$  = height of equivalent rectangle, equal to the greatest dimension across  $A_{ef}$ , perpendicular to the longest side of  $A_{ef}$ , mm (Figure 7.5.8.4.2)



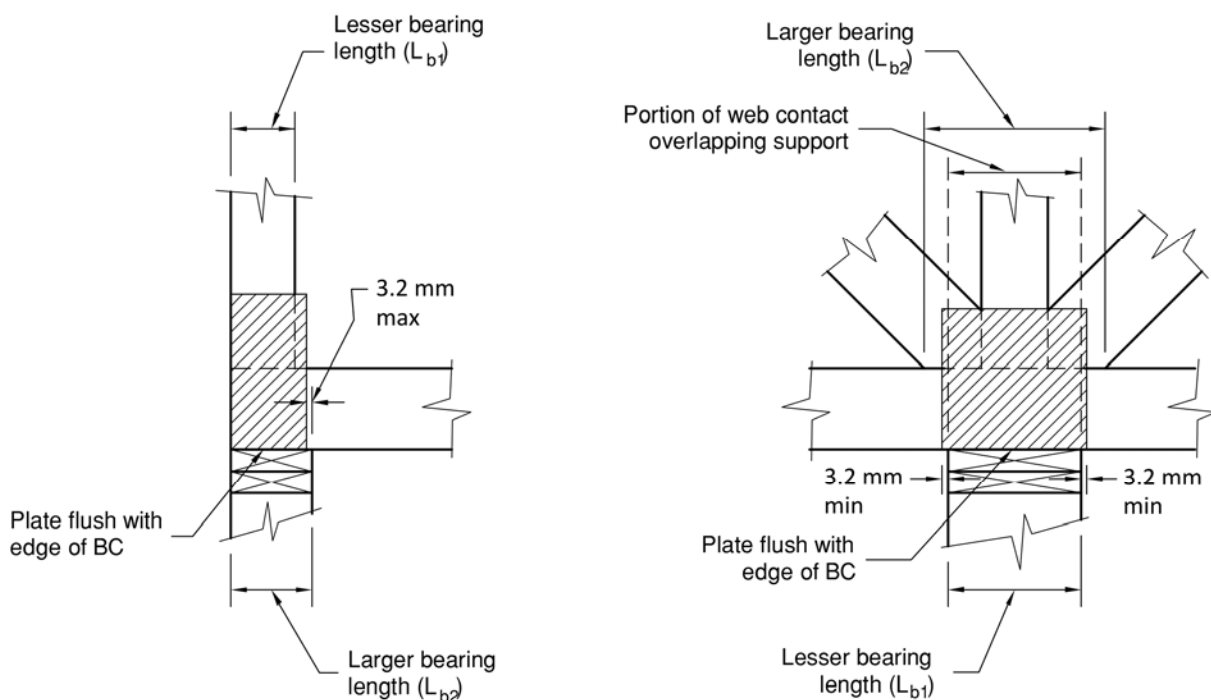
**Figure 7.5.8.4.2**  
**Design of plate lateral resistance for the effect of moment**

### 7.5.9 Compression perpendicular-to-grain reinforcement for sawn lumber

Any joint which carries a factored concentrated load that subjects the sawn lumber member to compression perpendicular-to-grain stresses through the depth of the member (example: the bottom chord on a bottom chord bearing flat truss) such that a reduction of bearing strength as described in Clause 6.5.4.3 applies, may be reinforced with connector plates so that the increased bearing strength of Clause 6.5.4.2 may be used. This bearing reinforcement consists of applying connector plates at the joint of a size that permit coverage of the chord member flush with the edge making contact with the bearing.

When using this reinforcement to reduce the required bearing size, the lesser of the web contact length that directly overlaps the support or the lesser bearing length ( $L_{b1}$ ) shall be used to calculate the bearing area in Clause 6.5.4.2. See Figure 7.5.9.

**Note:** the plate locations shown in Figure 7.5.9 are design locations and are subject to the 6.4 mm translation plate placement tolerances outlined in G.4.2.2 for actual location.



**Figure 7.5.9**  
**Compression perpendicular to grain reinforcement**

## **8. Manufacturing and material variances**

### **8.1 General**

The minimum quality manufacturing criteria including tolerances to allow for manufacturing variances shall be in accordance with Appendix G.

### **8.2 Quality control program**

All fabricators shall have a recognized quality control program that complies with the requirements of CWTA, "*National Quality Standard for Metal Plate Connected Wood Trusses.*"

### **8.3 Fingerjoined lumber**

When fabricating trusses using fingerjoined lumber graded per NLGA SPS 1 or NLGA SPS 4 fabricators shall conform to Annex A of CWTA, "*National Quality Standard for Metal Plate Connected Wood Trusses.*"

## **9. Truss design drawings**

In addition to the truss drawing itself, minimum design information to be included on the truss design drawing can be found in Appendix H.

## Appendix A

### Analogue Details

#### A.1 Analogue joint types

- (1) Pitch Break Joint: A joint formed by the intersection of two non-parallel chords (see Figure A.2).
- (2) Heel Joint: A pitch break joint consisting of a non-vertical top chord and non-vertical bottom chord (see Figure A.2).
- (3) Splice Joint: A joint formed by two parallel and adjacent chords (see Figure A.2.3).
- (4) Lapped Joint: A joint formed by one end of a chord placed parallel and in contact with the adjacent chord along one of its edges (see Figure A.2.4).
- (5) Web Joint: A joint formed by one or more webs along one edge of a given chord (see Figure A.2.5).
- (6) Internal Joint: A joint formed by two web joints on opposite edges of a given chord such that their contact lengths overlap along the axis of the chord (see Figure A.2.6).
- (7) Tail Bearing Joint: A joint consisting of a single member going to a support. (see Figure A.2.7)
- (8) Top Chord Bearing Joint: A joint consisting of two or more members connecting at an exterior support. (see Figure A.2.8.1)
- (9) Bearing Joint: A joint where a bearing touches a chord (see Figure A.2).

#### A.2 Analogue points

- (1) Simple Analogue Point: An analogue point consisting of only one point formed by two uniquely identifiable lines.
- (2) Compound Analogue Point: Analogue formed by two or more joints located at the same physical joint (see Figure A.2).
- (3) Except as in Clause A.2.9, analogue points shall be constructed as described in this section.

##### A.2.1 Heel analogue

The heel analogue is a compound analogue consisting of three simple analogue points and three fictitious members (see Figures A.2.1.A to A.2.1.G).

- (1) First analogue point shall be determined as follows:
  - (a) Construct a vertical line at the end of TC or BC member whichever is shorter. For Girder Heel, end of BC is always used to construct this line (see Figure A.2.1.B). The only exception to this rule is in the case of a short cantilever. If the bearing occurs inside the point where the top chord terminates then this line is constructed at the end of the top chord and is considered the design span (see Appendix B).
  - (b) Find the intersection of the vertical line with the centrelines of the TC and BC. First heel analogue point shall be the lower of the two intersection points. This is the bearing point except as mentioned in Clause A.2.1(6).
- (2) The second heel analogue point shall be located at the intersection of the centreline of BC and a vertical at 75% of scarf length from the first analogue point. This vertical may not be more than 610mm away from the first analogue point.
- (3) The third heel analogue point shall be located along the centreline of the top chord directly above the second heel analogue point.
- (4) Where the second and the third points are closer to the first point than 51 mm, remove the second and third points and reduce the heel analogue to simple analogue.
- (5) In the case of a reinforcing wedge, the second heel analogue point shall be located at the intersection of the centreline of the BC and, a vertical at 75% of the combined BC and wedge scarf lengths, from the first analogue point. This vertical may not be more than 610 mm away from the first analogue point.
- (6) In the case of a reinforcing member, a fourth point is required. The reinforcing member acts as the fourth member. The fourth point is the intersection of the centreline of the chord with a line perpendicular to the chord at a distance "d/2" where "d" is the depth of the chord (see Figures A.2.1.C and A.2.1.D).
- (7) In the case of a reinforcing web, the analogue is similar to the reinforcing member analogue with the following exceptions:

- (a) The fourth analogue point is the analogue point of the adjacent joint.
- (b) The fourth member is the reinforcing web.
- (c) The bearing point is the first analogue point only if all of the bearing surface falls between the first and second analogue points inclusive (see Figures A.2.1.C and A.2.1.E). Short cantilever and high heel rules apply (see Appendix B).
- (d) If any part of the bearing surface falls past the second analogue point, the bearing point is at the second analogue point or a new bearing joint is introduced depending on the contact between the bearing surface and the scarf of the reinforcing web (see Figure A.2.1.F). Short cantilever and high heel rules do not apply for this condition.
- (e) If the reinforcing web is not fully parallel and touching the chord, two separate joints are constructed; a heel joint and a web joint (see Figure A.2.1.G).

### **A.2.2 Pitch break analogue point**

- (1) The pitch break analogue point shall be located along a plumb line through the outside edge intersection of the two chords. The analogue point shall have the same X coordinate as the plumb location and Y coordinate equal to the average Y coordinates formed by intersection points of the chord centrelines and the plumb line (see Figure A.2.2.A).
- (2) In case of a mitre cut pitch break, the analogue point is the intersection of the centrelines of the chords (see Figure A.2.2.B). For corner joints, the analogue point shall be the intersection of the centreline of the chord and a line at the end of the chord (see Figure A.2.2.C).

### **A.2.3 Splice joint analogue point**

A splice joint analogue point shall be the point located at the halfway point between the intersection points of the centrelines of the two chord members and the splice line (see Figure A.2.3).

### **A.2.4 Lapped joint analogue point**

A lapped joint analogue point shall be the point located at the halfway point between the intersection points formed by the end cut and centrelines of the chord members on the two sides of the joint (see Figure A.2.4).

### **A.2.5 Web joint analogue point**

A web joint analogue point shall be the intersection of the centrelines of chord and a line perpendicular to the chord passing through the centre of contact area between the webs and the chord (see Figures A.2.2 and A.2.5).

### **A.2.6 Internal joint analogue point**

An internal joint analogue point shall be the intersection of the centreline of chord and a perpendicular through the centre of common contact area, from both sides, between the webs and the chord (see Figure A.2.6).

### **A.2.7 Tail bearing joint analogue point**

A tail bearing joint analogue point shall be at the intersection of the centreline of the chord and a vertical through outside corner of support. For a vertical tail bearing, use the horizontal through the outside corner of bearing instead of the vertical (see Figure A.2.7).

### **A.2.8 Top chord bearing**

Top chord bearing joint guidelines in Clause 6.7.6 must be observed when using the analogues described in Clause A.2.8.

### **A.2.8.1 Top chord bearing joint**

Except as provided in Clause A.2.8.2, a top chord bearing joint analogue is compound and consists of two points. The first point is the bearing point and it is the intersection of the centreline of the top chord with a vertical along the inside face of the bearing. The second point is the intersection of the centreline of the top chord with a vertical through the outside edge of any webs coming to the top chord at the bearing. The maximum distance allowed between these points is 89 mm (see Figure A.2.8.1 and Appendix E).

### **A.2.8.2 Top chord bearing joint with end vertical and block**

The analogue of this point is compound and consists of three points and two fictitious members. The first joint is the bearing point and it is the intersection of a vertical through centreline of the required bearing size and surface of bearing. The second point is the intersection of a horizontal through the first point and the outside edge of end vertical. The third point is intersection of the centreline of the top chord and the outside edge of end vertical (see Figure A.2.8.2).

## **A.2.9 Analogue modifications**

### **A.2.9.1 Analogue heirarchy**

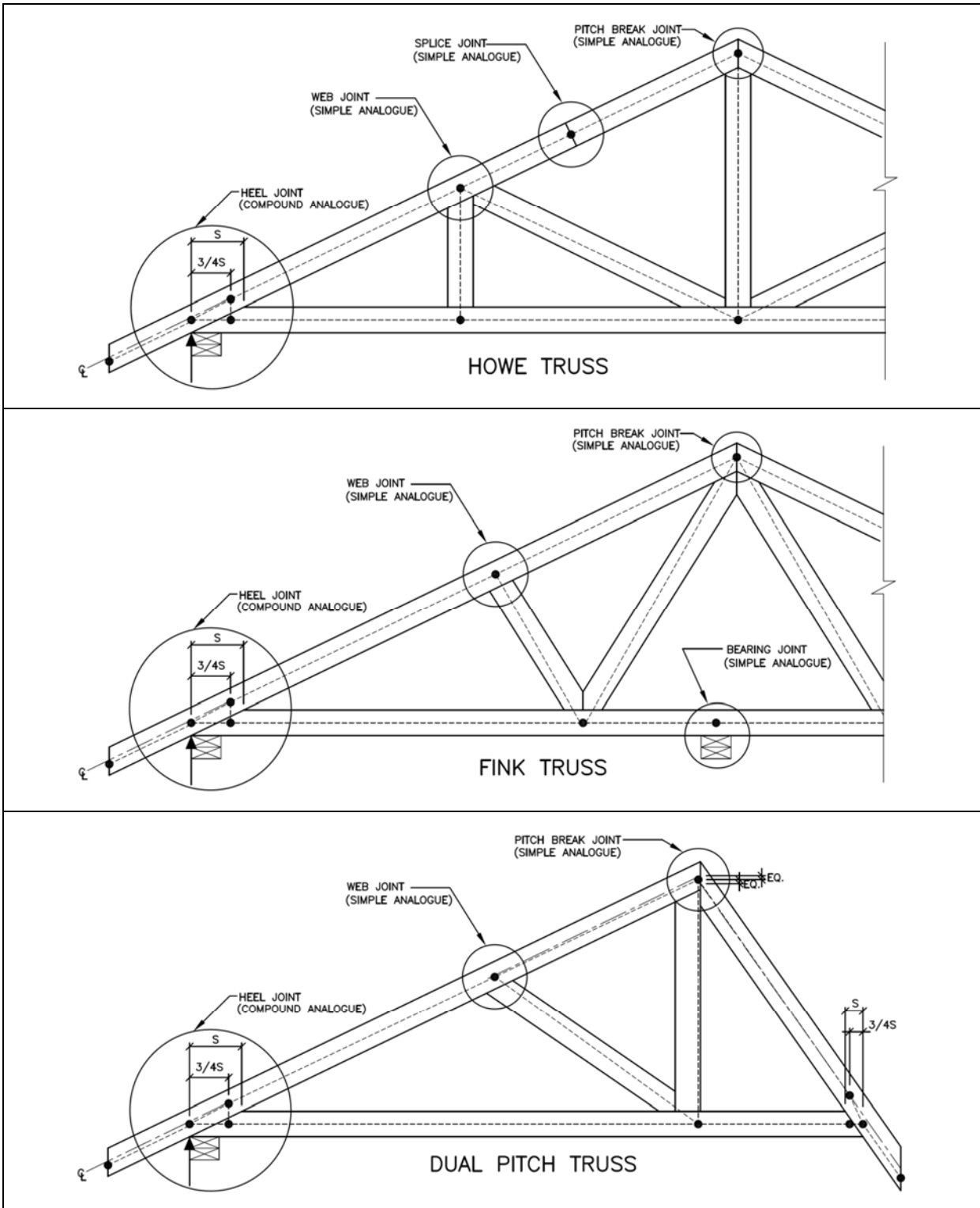
Analogue points shall be constructed using the following heirarchy: Pitch break joints, then, most member to least member web joints. All other joints not mentioned here may be constructed in any order.

### **A.2.9.2**

Analogue points for joints connected by a vertical web to joints of higher hierarchy shall be obtained as intersection of vertical through the higher hierarchy joint and the centreline of chord.

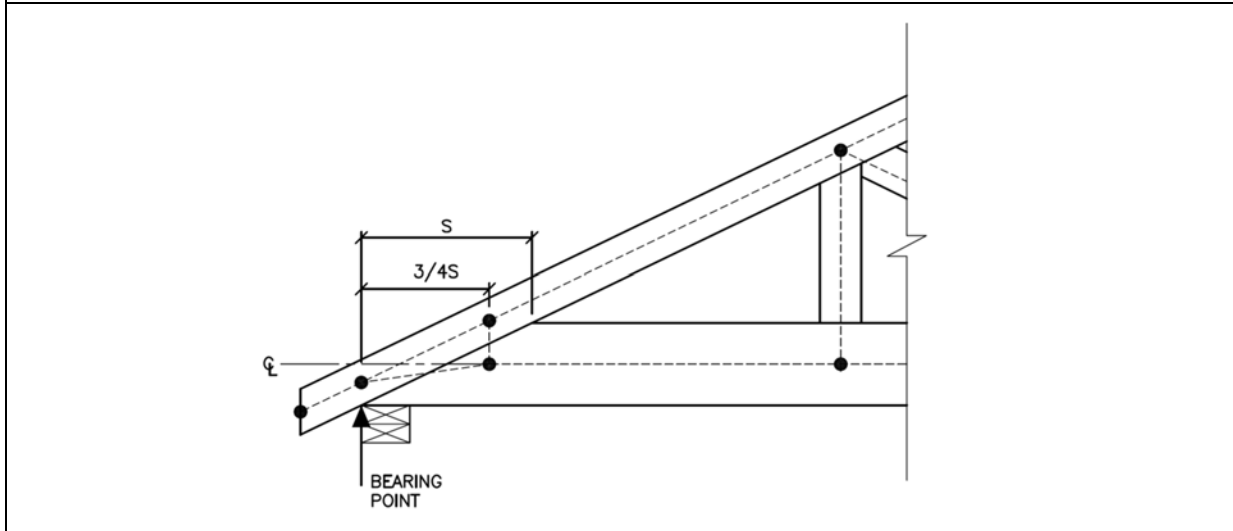
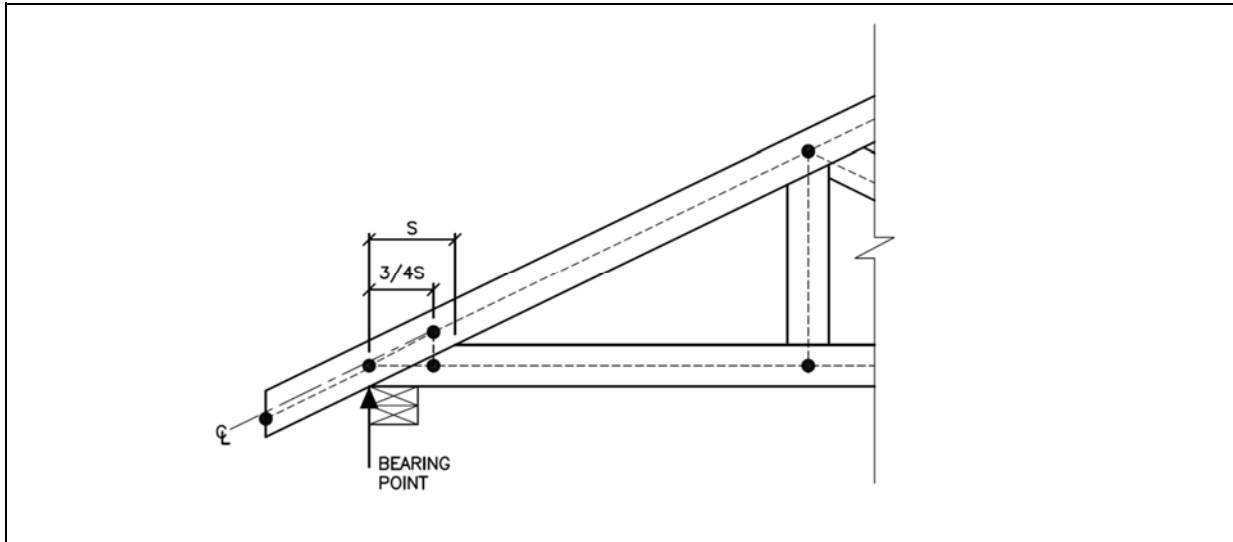
### **A.2.9.3**

Two analogue points closer to each other than 51 mm (unprojected) shall be reduced to one joint located between the two original joints.

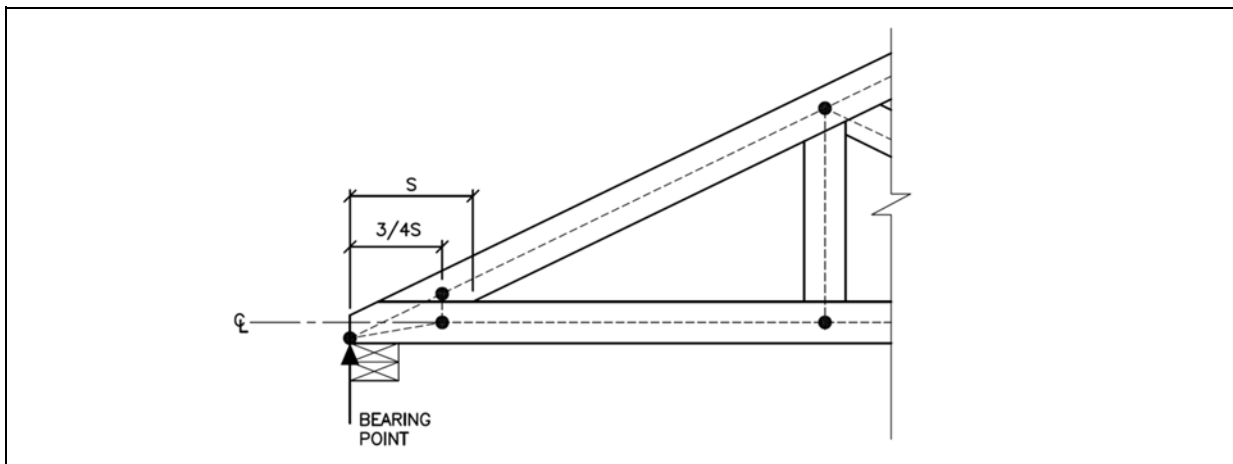


**Figure A.2**  
Simple and compound analogue





**Figure A.2.1.A – Standard heel analogue**



**Figure A.2.1.B – Girder heel**

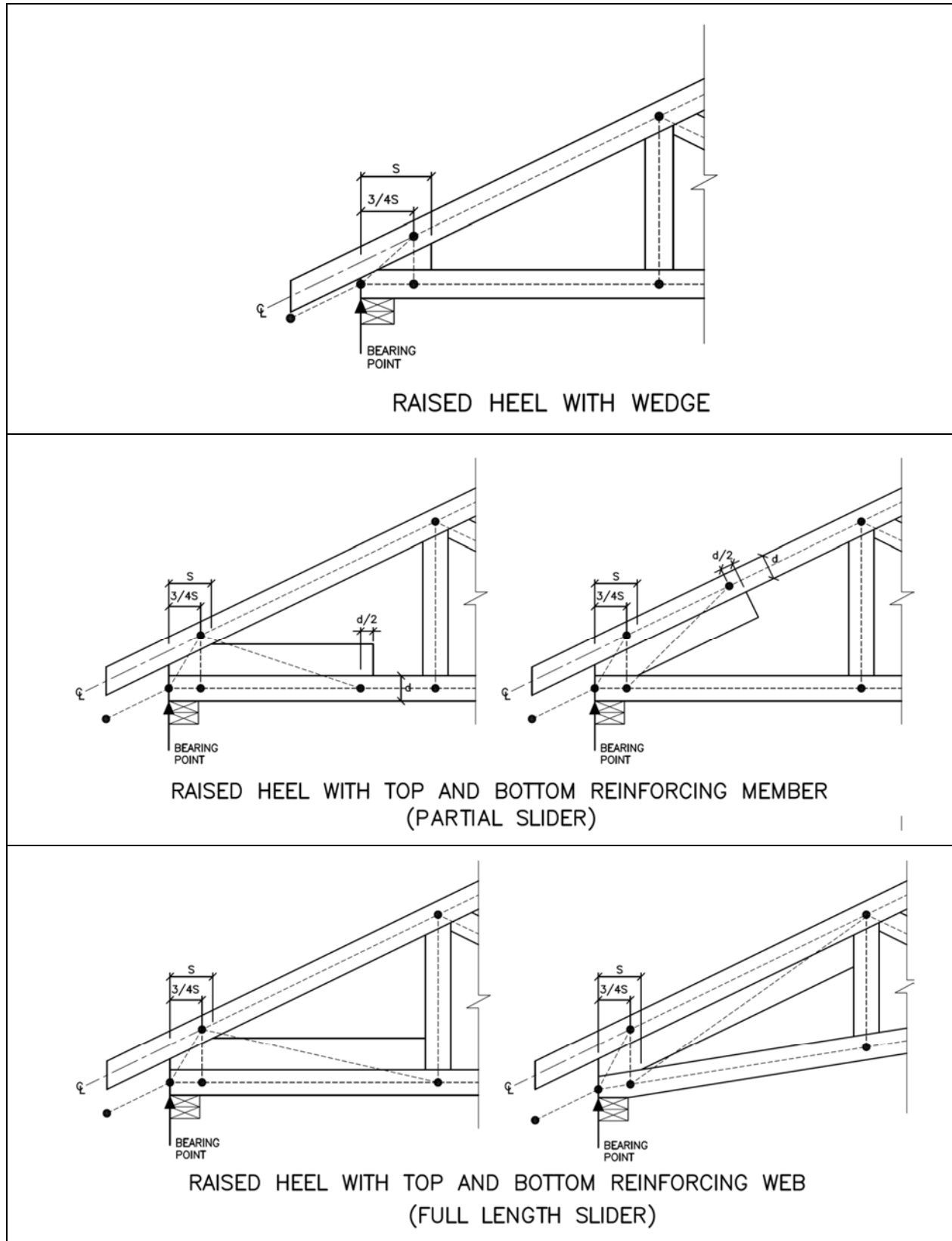


Figure A.2.1.C – Raised heels

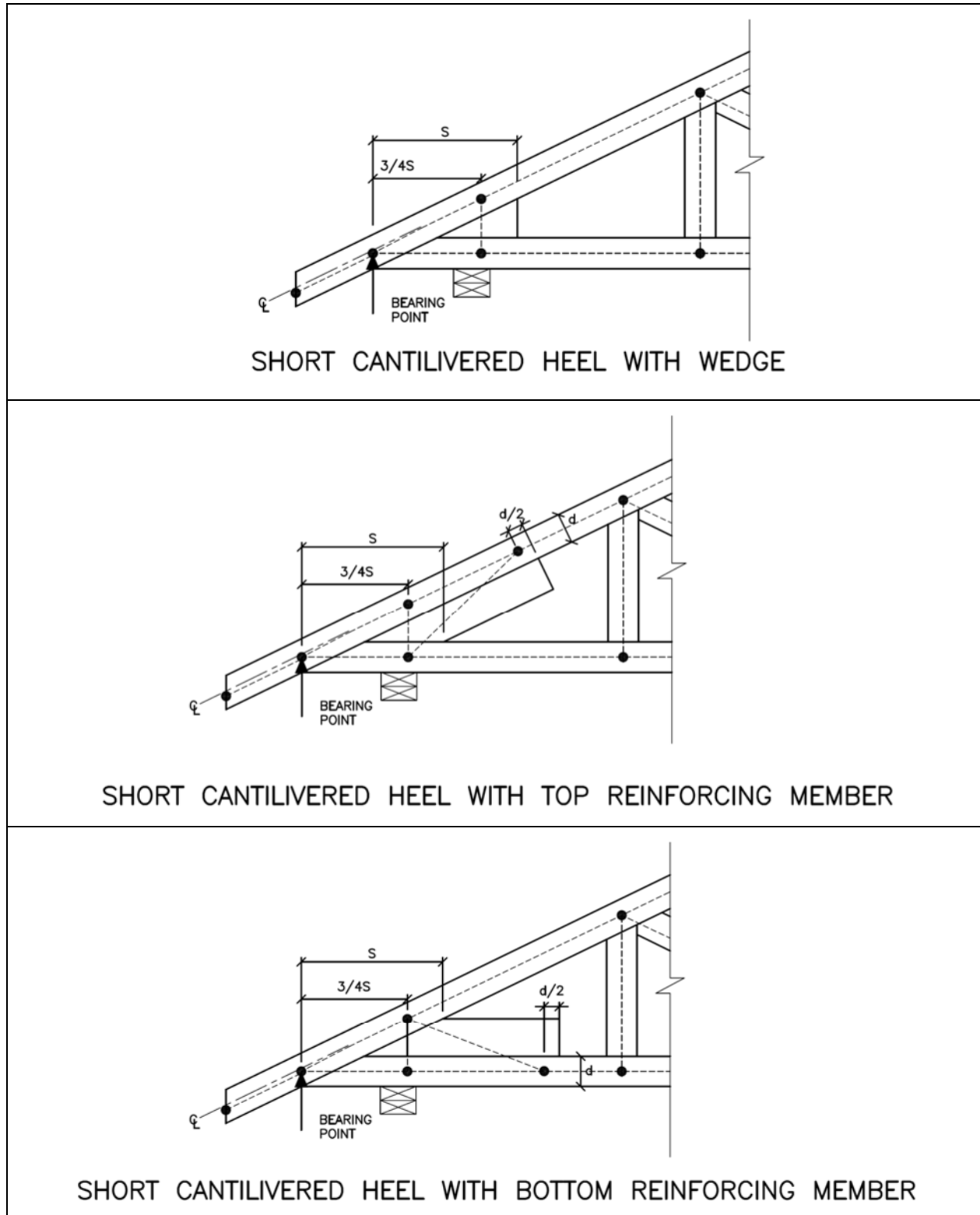
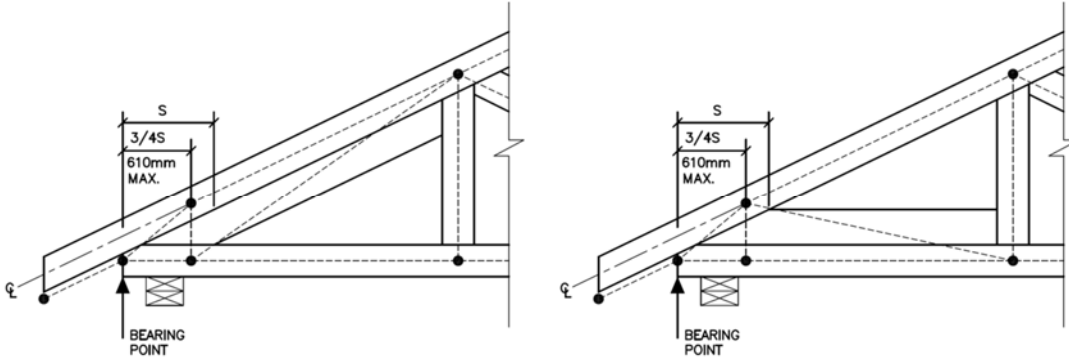
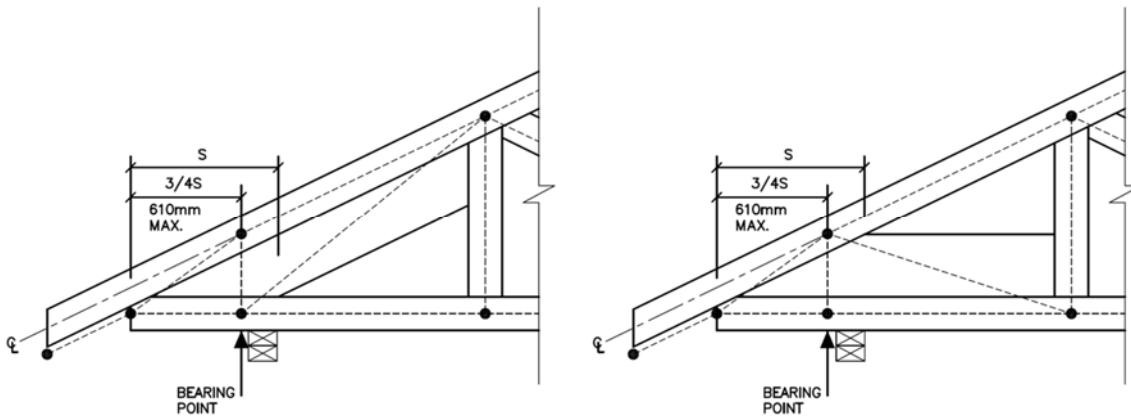


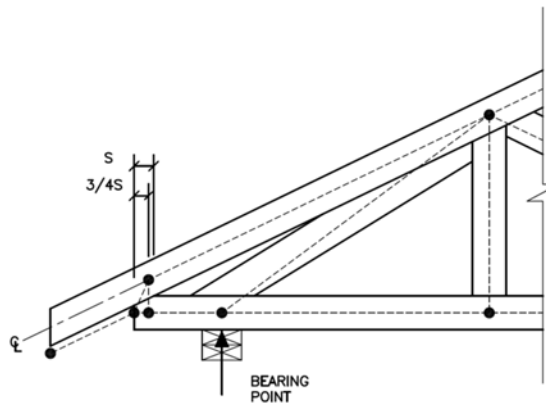
Figure A.2.1.D – Short cantilevered heels



**Figure A.2.1.E – Short cantilevered heel with top and bottom reinforcing web. Bearing point at first analogue point**



**Figure A.2.1.F – Cantilevered heel with top and bottom reinforcing web. Bearing point at second analogue point**



**Figure A.2.1.G – Cantilevered heel with two separate joints**

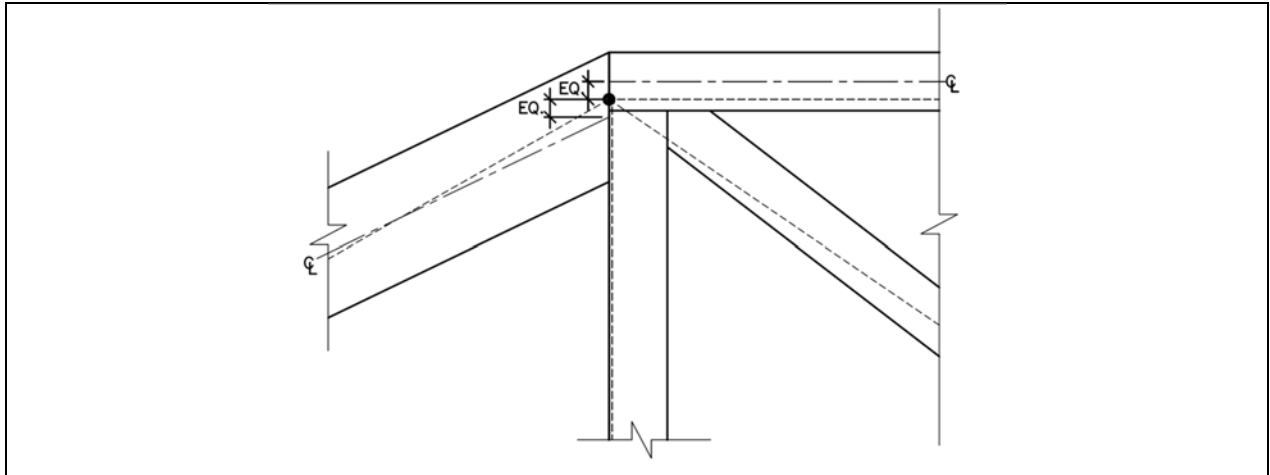


Figure A.2.2.A – Pitch break joint

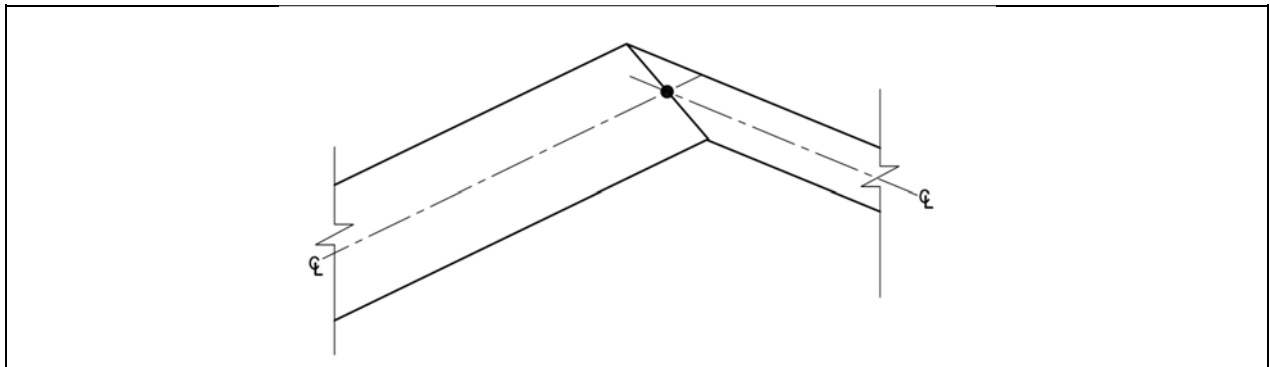


Figure A.2.2.B – Mitre cut pitch break joint

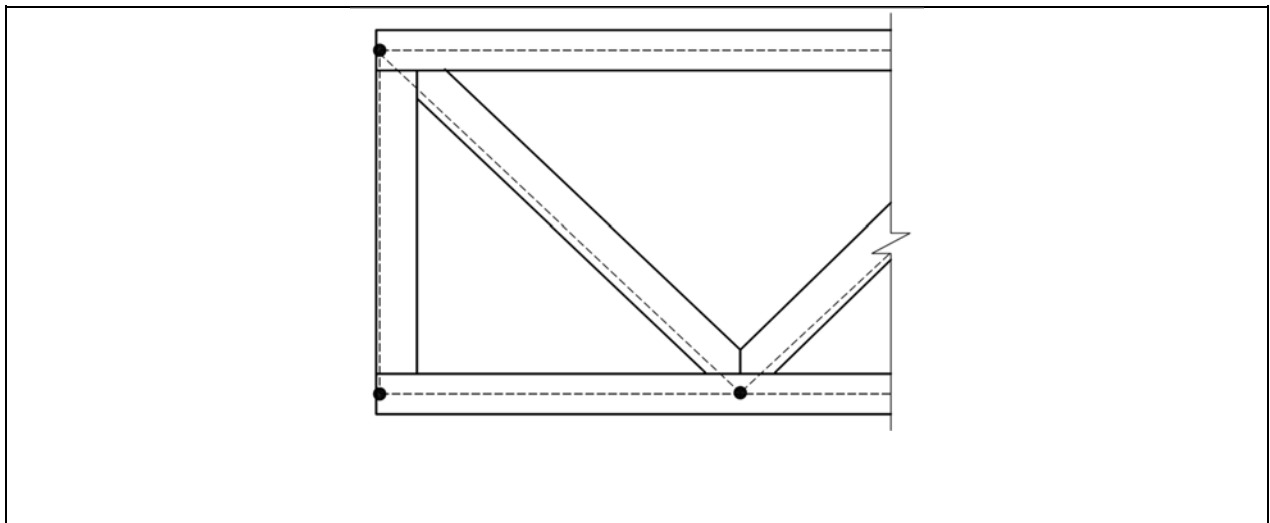


Figure A.2.2.C – Corner joint

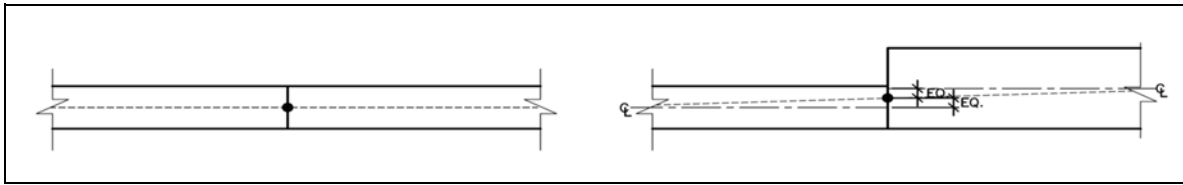


Figure A.2.3 – Splice joint

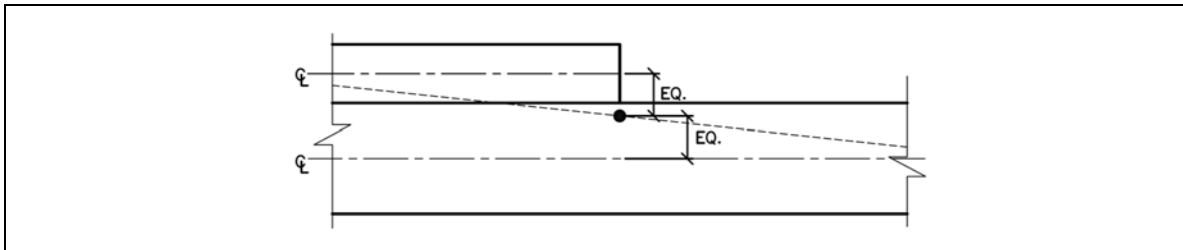


Figure A.2.4 – Lapped joint

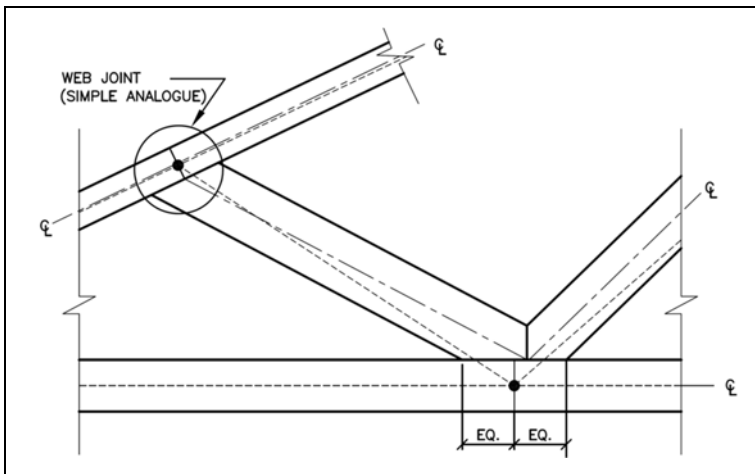


Figure A.2.5 – Web joints

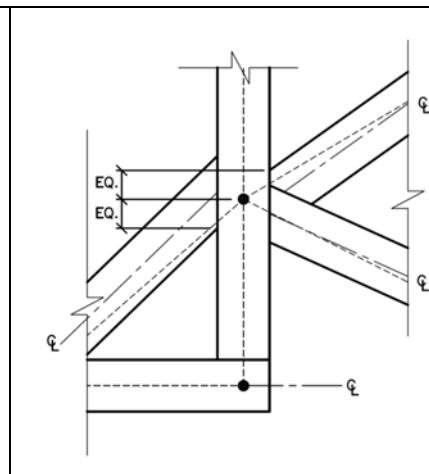


Figure A.2.6 – Internal joint

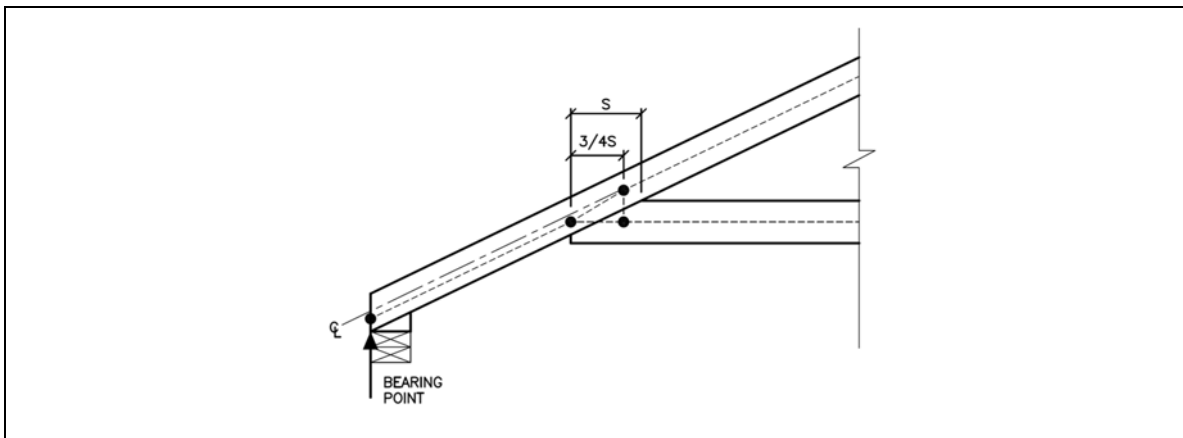


Figure A.2.7 – Tail bearing joint

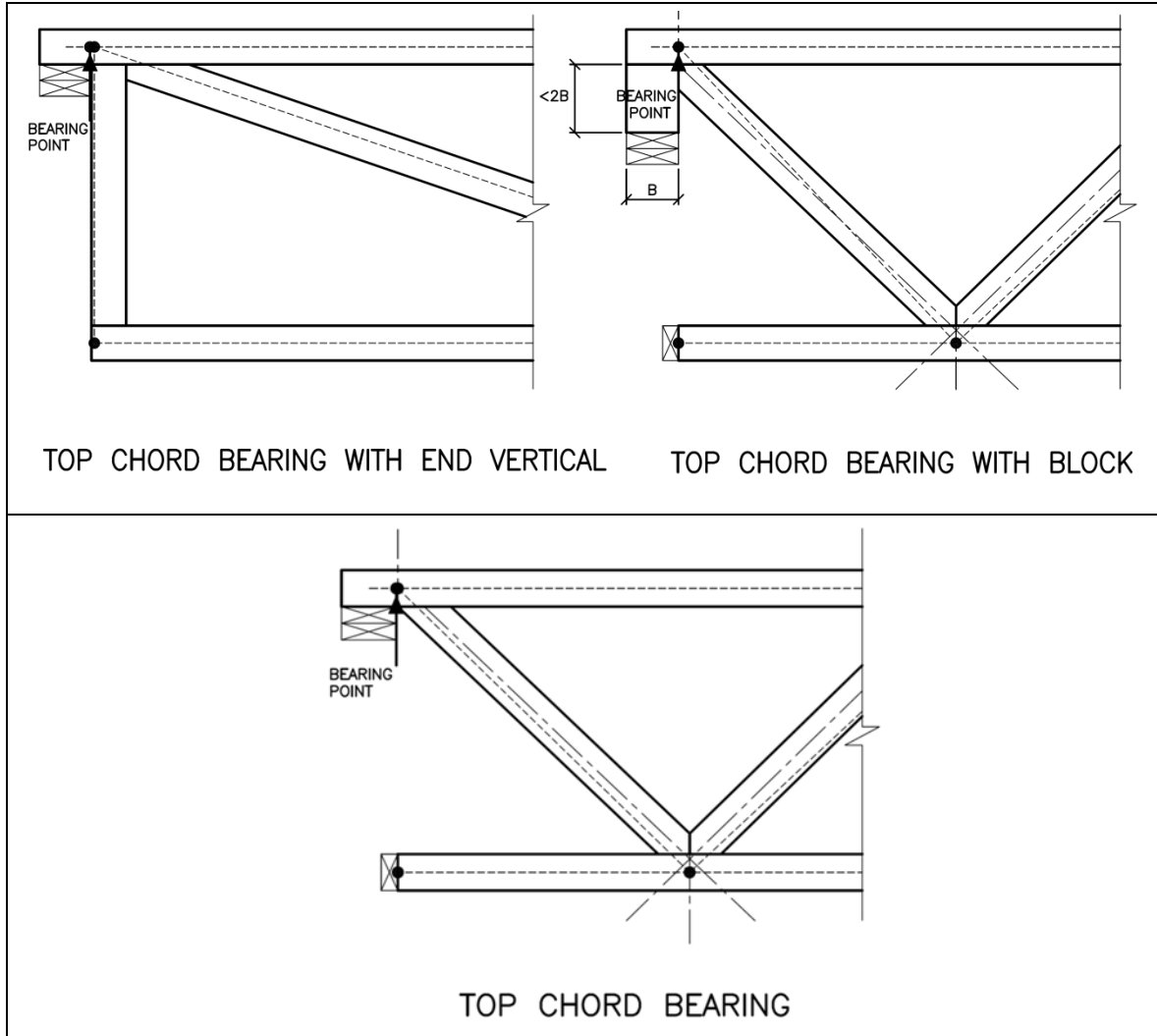


Figure A.2.8.1 – Top chord bearing details

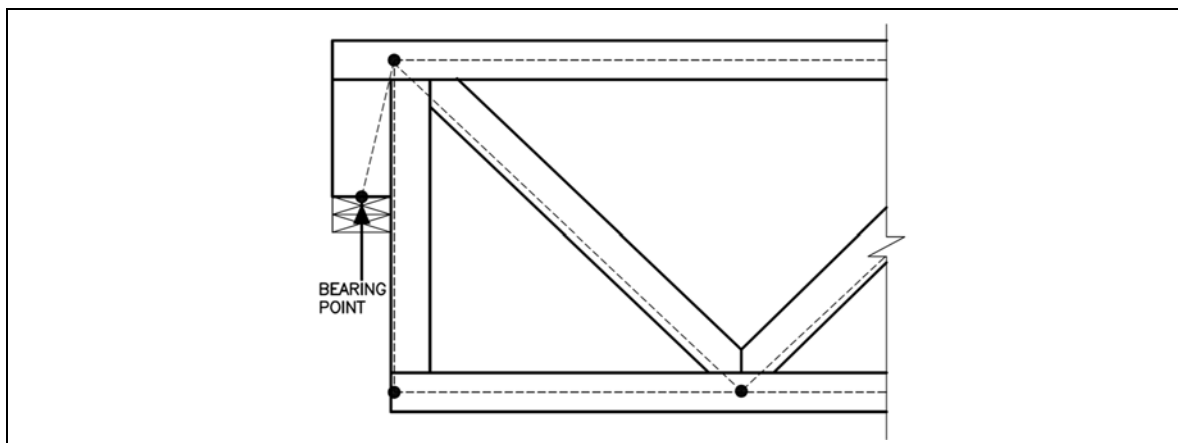


Figure A.2.8.2 – Top chord bearing with end vertical and block

## Appendix B

### Design of short cantilevers and heel cuts

#### B.1 General

- (1) Design span is always out to out of bottom chord for standard details.
- (2) The sum of cantilever lengths shall not exceed 25% of span between bearings.
- (3) Maximum cantilever shall not exceed 1372 mm.
- (4) The TPIC standard procedures for plating heel joints shall apply. i.e. Reduction of grip value with slope increase.
- (5) Partial reinforcing members used with short cantilevers and heel cuts are limited in scope to trusses designed using the Modified Formula (Clause 6.5.12.2). The reinforcing members shall be designed for top or bottom chord forces as applicable. For all other applications these cantilevers and heel cuts must be accomplished by full length reinforcement of the appropriate chord and limitations of cantilever length, reinforcement size, species, grade and, plating to be determined by analysis.

#### B.2 Short cantilever details

##### B.2.1 Maximum cantilever dimension

For all details, the maximum values of 'C' must be calculated for specific slope and heel cut as shown in the details.

##### B.2.2 Without reinforcing

Plate heel for actual chord force. A tie plate is recommended for long scarf cuts. See Detail B.2.2.

##### B.2.3 With wedge reinforcing

Plate heel for actual forces. Tie plates are always required with the wedge. Total area of tie plates on chords shall be 20% of required area of heel plate on corresponding chord. See Detail B.2.3.

##### B.2.4 With chord reinforcing (Detail B.2.4.A and Detail B.2.4.B)

- (1) Plates joining reinforcing member to parallel chord shall provide sufficient grip and shear length to transfer full chord force to reinforcing member. Where only one plate is used, it shall be designed for 1.20 times chord force.
- (2) Heel shall be designed as per standard heel procedures. Reinforcing member may be considered as top or bottom chord as applicable. There shall be a minimum of 25 mm overlap as shown in sketches.
- (3) Where plating and scarf permit, the reinforcing member may form part of the heel cut.
- (4) Tie plates are recommended for long scarfs.

#### B.3 Heel Cuts

##### B.3.1 Heel cuts $\leq$ half the depth of the bottom chord (Detail A)

Heel cut less than or equal to 6.4 mm may be considered as zero heel cut. Plate for full chord forces.

##### B.3.2 Heel cuts $\leq$ the depth of the bottom chord (Detail B)

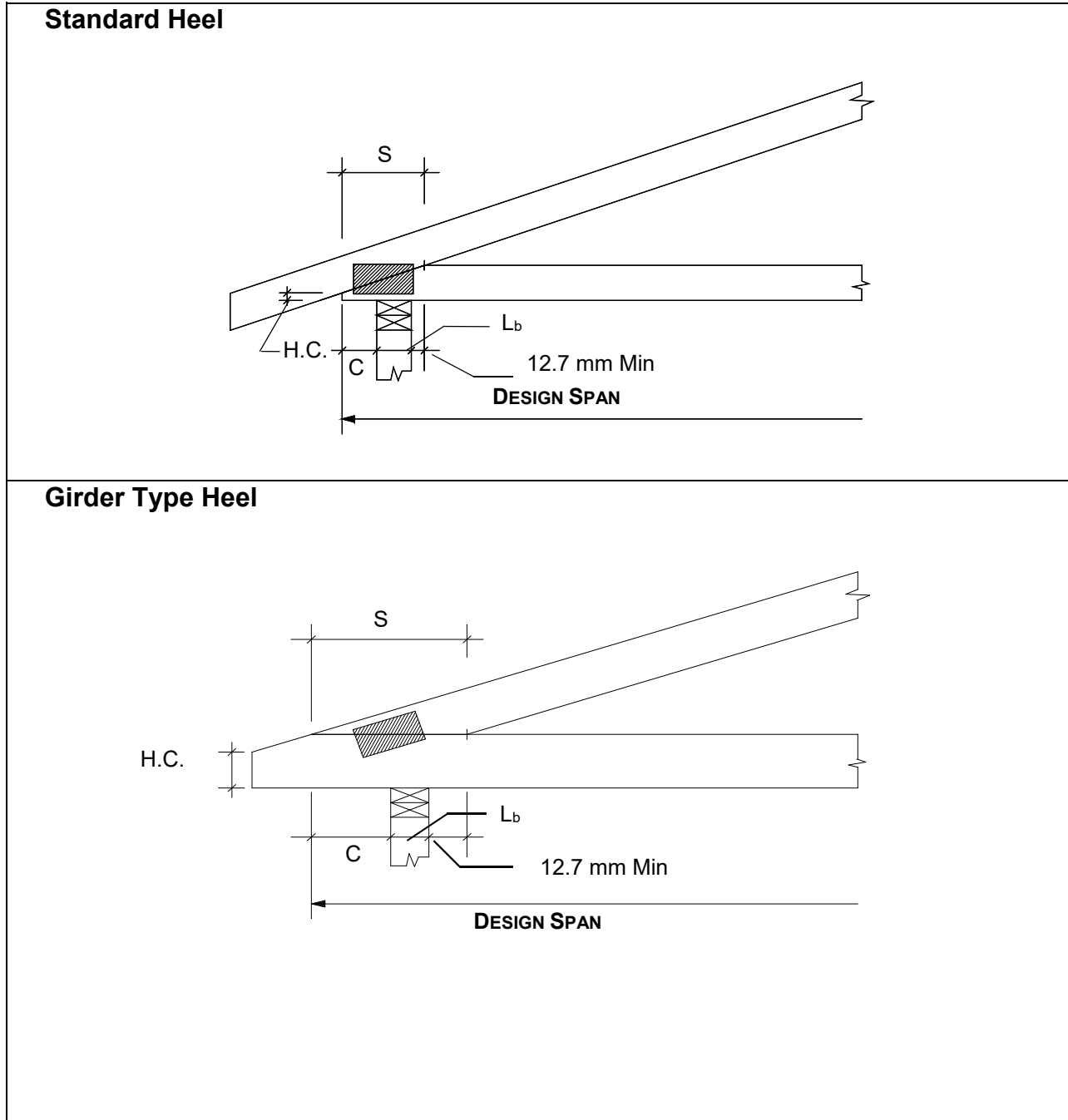
Plate heel to resist full chord forces at 1/2 bottom chord depth with linear interpolation to twice the full chord forces up to the full depth of bottom chord.

##### B.3.3 Heel cut $>$ the depth of the bottom chord (Detail C)

Plate heel for full chord forces. Plate design for connecting reinforcing member to parallel chord shall be as per Clause B.2.4(1).



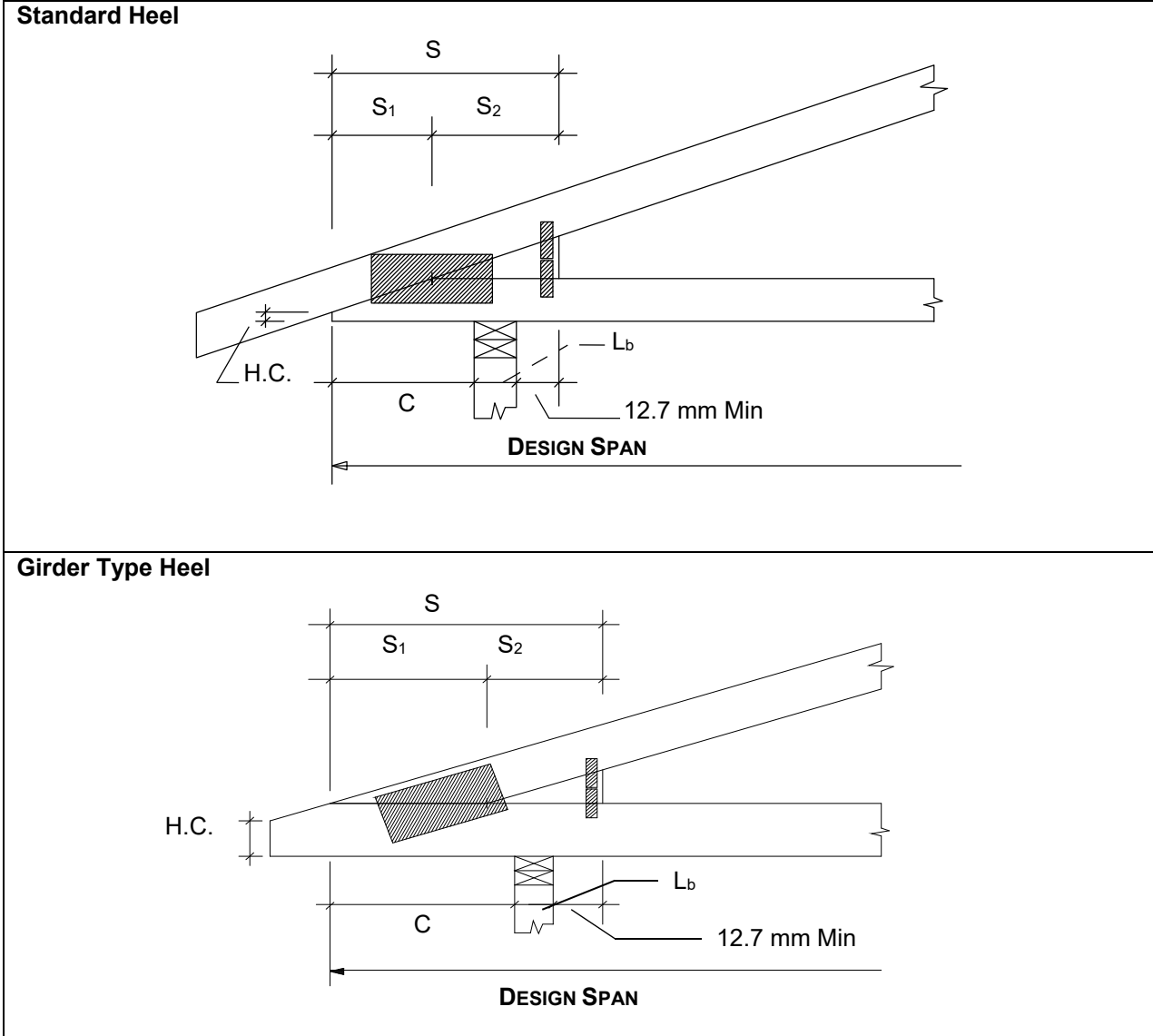
Detail B.2.2 – Short Cantilevers without Reinforcing



Maximum cantilever "C" calculation

$$C = S - L_b + 12.7 ; \text{mm}$$

Detail B.2.3 – Short cantilevers with wedge reinforcing

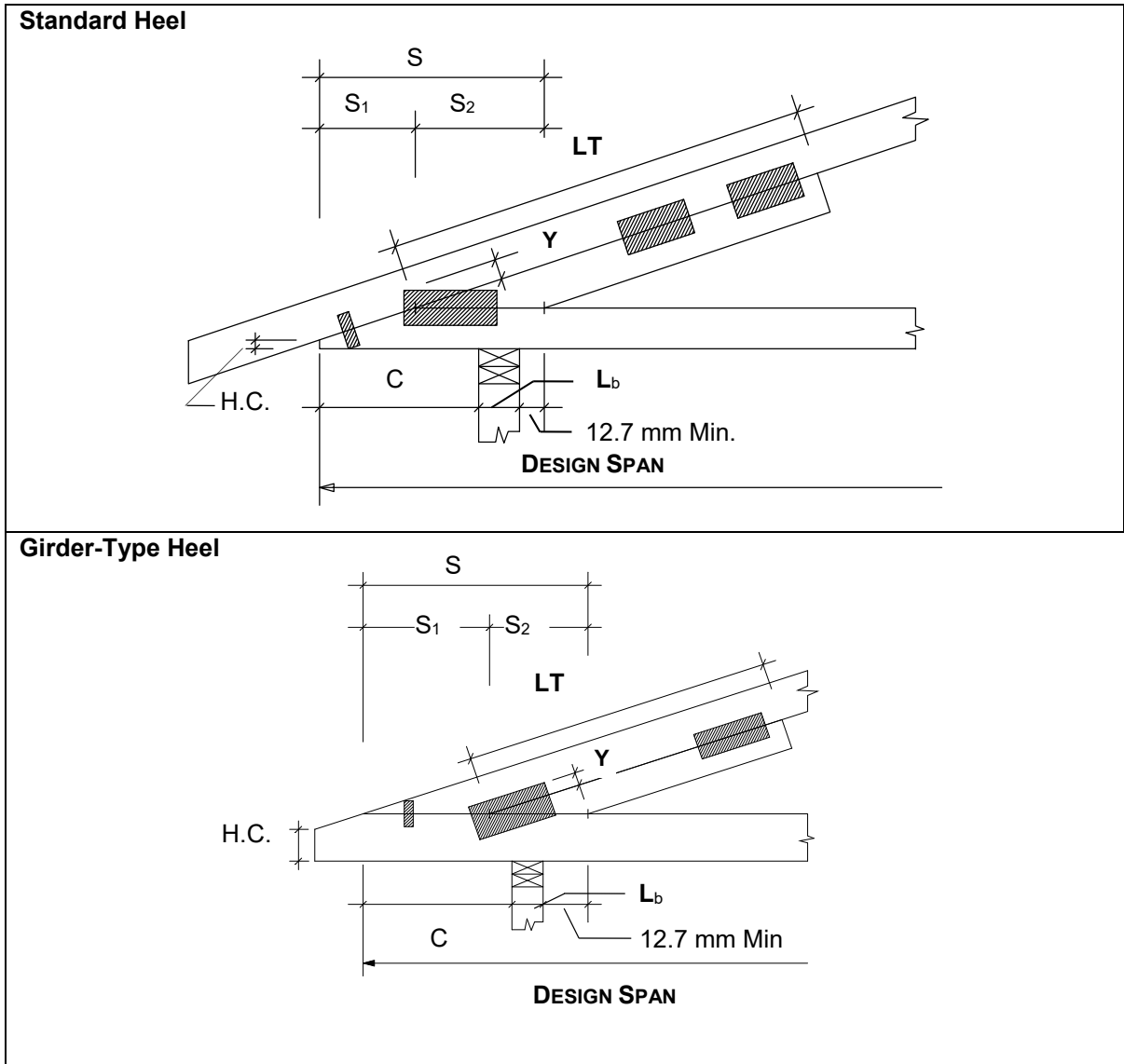


Maximum cantilever “C” calculation

$$C = S_1 + 89; \text{ mm}$$

**Note:** The maximum value for  $S_2$  in determining analogue distance  $S$  is that calculated for a wedge depth equalling the bottom chord depth

**Detail B.2.4.A – Short cantilevers with partial top chord reinforcing member  
(partial top chord slider)**

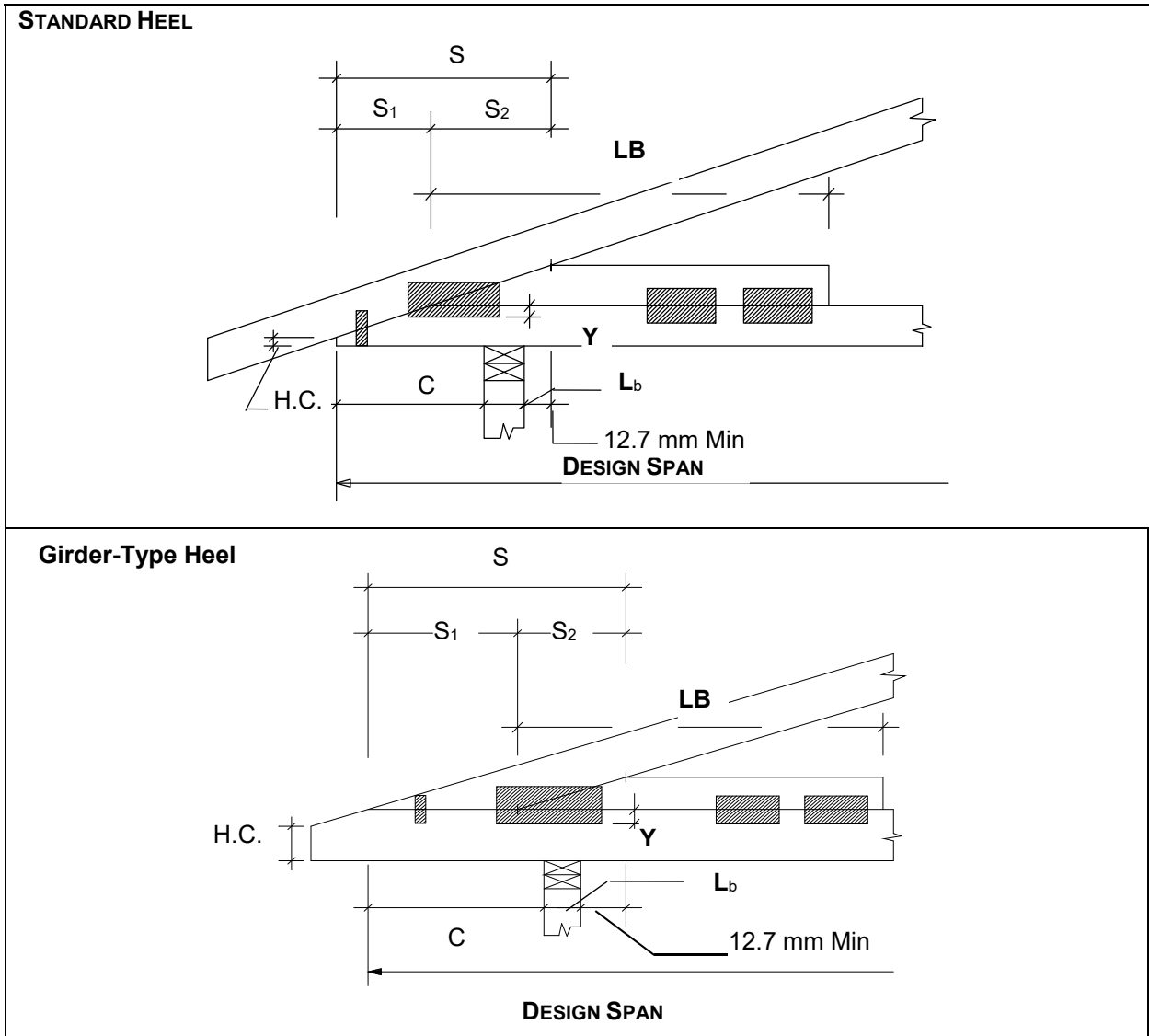


Maximum cantilever "C" calculation

$$C = S_1 + S_2 - (L_b + 12.7) ; \text{ mm}$$

- |        |  |
|--------|--|
| Notes: | 1. Maximum value of $S_2$ is limited by maximum reinforcing member size 38x184 |
|        | 2. $LT$ = Minimum of one half the length of top chord panel                    |
|        | 3. $Y$ = Minimum of 25 mm  |

**Detail B.2.4.B – Short cantilevers with partial bottom chord reinforcing member  
(partial bottom chord slider)**

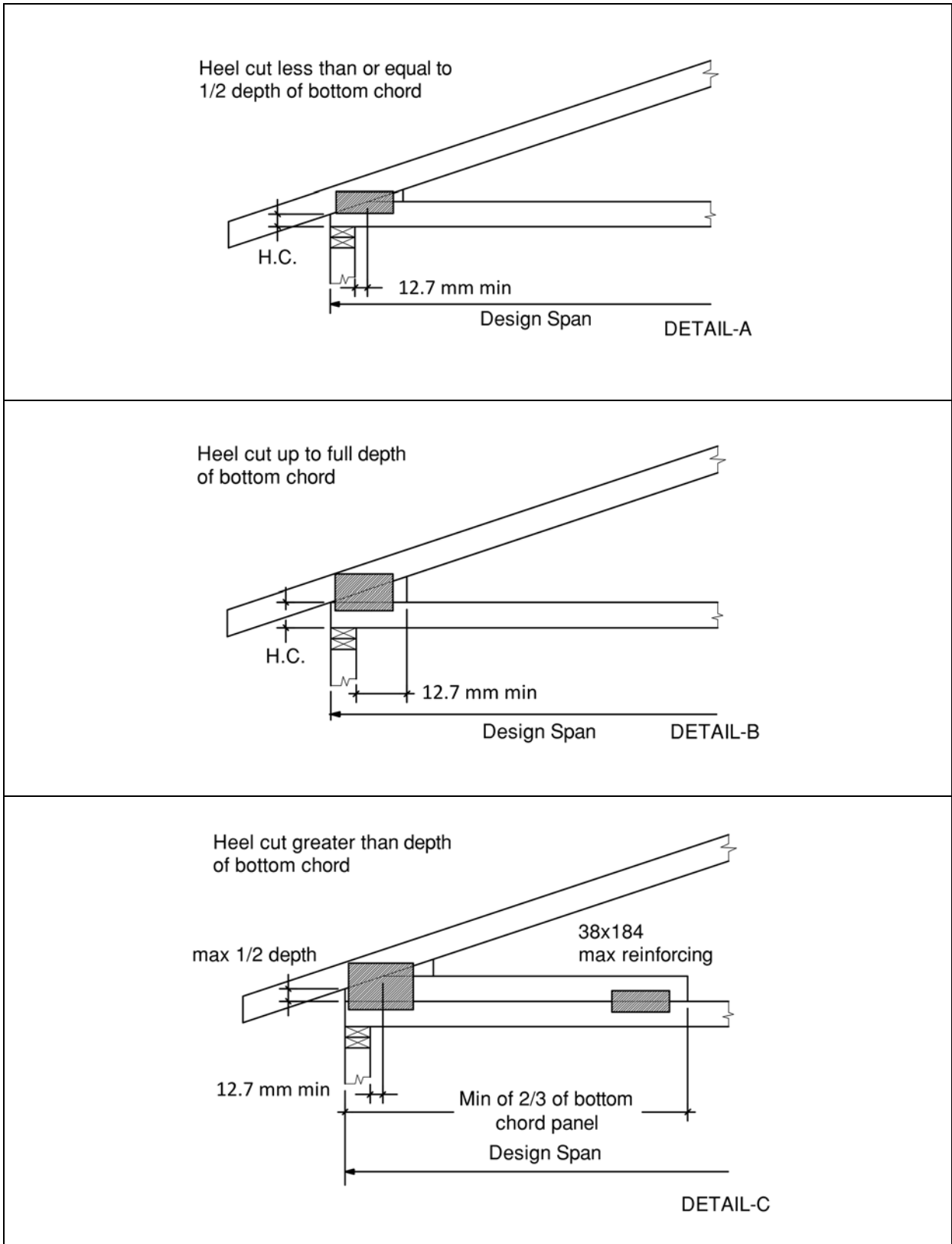


Maximum cantilever "C" calculation

$$C = S_1 + S_2 - (L_b + 12.7) ; \text{ mm}$$

- |        |  |
|--------|--|
| Notes: | 1. Maximum value of $S_2$ is limited by maximum reinforcing member size 38x184 |
|        | 2. $L_b$ = Minimum of two thirds the length of bottom chord panel              |
|        | 3. $Y$ = Minimum of 25 mm  |

**Detail B.3 – Heel cuts**



## Appendix C

### Ply-to-ply laminating of girder trusses

**Table C.1.1**  
**Nail Spacing and Maximum/Minimum Number of Rows**

Minimum nail length	76 mm
Minimum nail diameter	3.66 mm
Lumber Species	Spruce-Pine-Fir
Minimum nail spacing parallel to grain	64 mm
Minimum nail spacing from End distance parallel to grain	45 mm
Minimum nail spacing perpendicular to grain	32 mm
Minimum nail spacing from edge distance perpendicular to grain	19 mm

Maximum kN/m apply only to nails as defined in CSA B111.

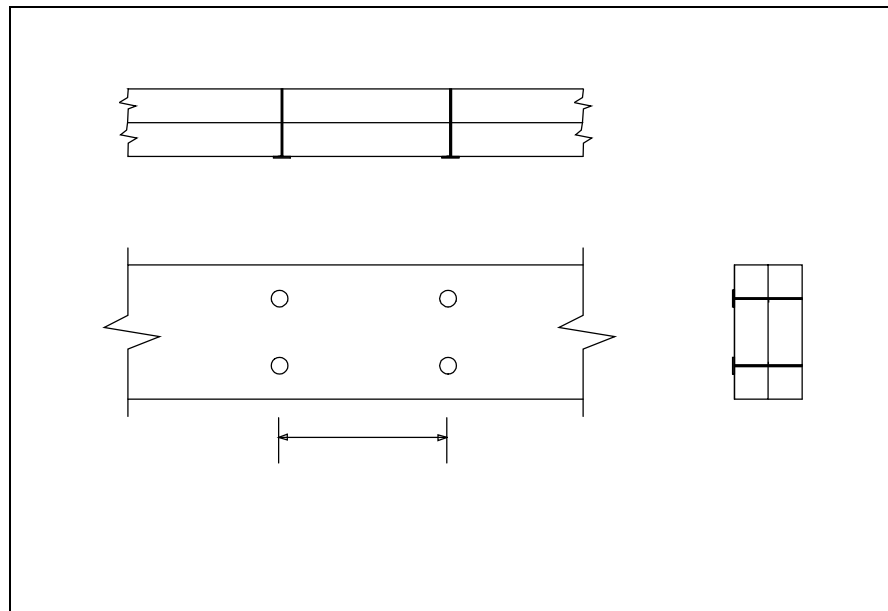
Member Depth (mm)	Maximum Number of Rows	Minimum * Number of Rows
64	1	1
89	2	1
114	2	1
140	3	2
184	4	2
235	5	3
286	6	3

\* For web nailing, use minimum number of rows stated in table and a surface nail spacing of 150 mm o.c.

**Table C.1.2**  
**Maximum Factored Load Applied to Outer Lamination of**  
**2-Ply Girder Truss with 76 mm Nails and S-P-F Lumber kN/m**

NUMBER OF ROWS	SURFACE NAIL SPACING, mm		
	305	152	102
1	4.64	9.28	13.92
2	9.28	18.56	27.84
3	13.92	27.84	41.77
4	18.56	37.13	55.69
5	23.20	46.41	69.61
6	27.84	55.69	83.53

- NOTE: 1) Load duration factor for “Standard Term” loading has been used in the computation of data in the table.  
 2) If 3-inch power driven nails (3.05 mm dia) are to be substituted for 76 mm common wire nails then reduce the maximum kN/m to be transferred by a factor of 0.71.  
 3) These tables are based on trusses fabricated using dry untreated lumber used in dry service conditions only.



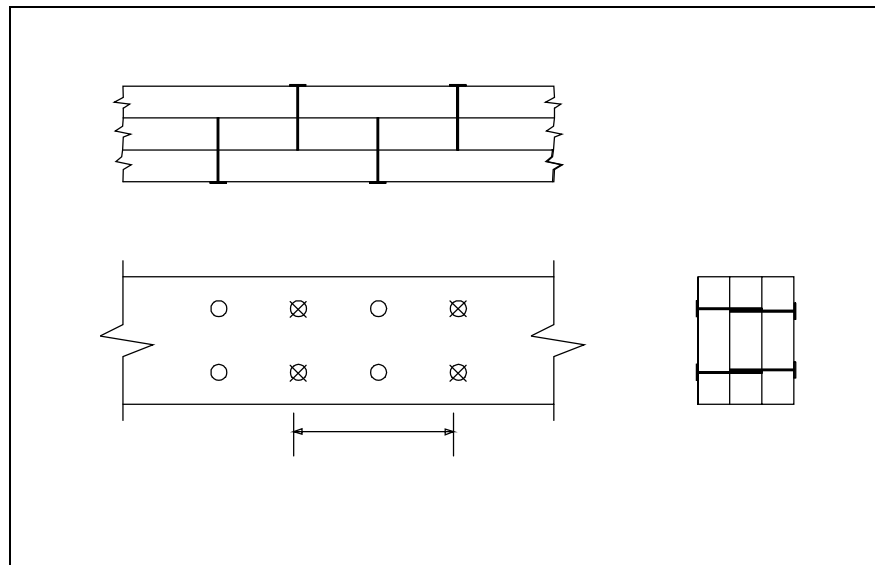
**Figure C.1.2 – Nailing Pattern for 2-Ply Girder**

**Table C.1.3**  
**Maximum Factored Load Applied to Outer Lamination of**  
**3-Ply Girder Truss with 76 mm Nails and S-P-F Lumber kN/m**

NUMBER OF ROWS	SURFACE NAIL SPACING, mm		
	305	152	127*
1	3.48	6.96	8.35
2	6.96	13.92	16.71
3	10.44	20.88	25.06
4	13.92	27.84	33.41
5	17.40	34.81	41.77
6	20.88	41.77	50.12

\* Inner ply rows should be offset for spacing

- NOTE:
- 1) Load duration factor for “Standard Term” loading has been used in the computation of data in the table.
  - 2) If 76 mm 3-inch power driven nails (3.05 mm dia) are to be substituted for 76 mm common wire nails then reduce the maximum kN/m to be transferred by a factor of 0.71.
  - 3) These tables are based on trusses fabricated using dry untreated lumber used in dry service conditions only.



**Figure C.1.3 – Nailing Pattern for 3-Ply Girder**

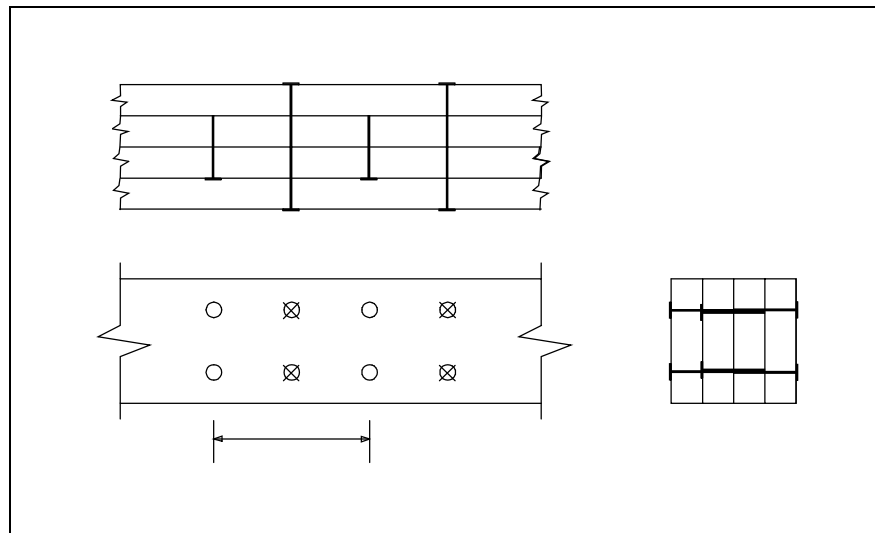


**Table C.1.4**  
**Maximum Factored Load Applied to Outer Lamination of**  
**4-Ply Girder Truss with 76 mm Nails and S-P-F Lumber kN/m**

NUMBER OF ROWS	SURFACE NAIL SPACING, mm		
	305	152	127*
1	3.09	6.19	7.43
2	6.19	12.38	14.85
3	9.28	18.56	22.28
4	12.38	24.75	29.70
5	15.47	30.94	37.13
6	18.56	37.13	44.55

\* Inner ply rows should be offset for spacing

- NOTE:
- 1) Load duration factor for “Standard Term” loading has been used in the computation of data in the table.
  - 2) If 76 mm power driven nails (3.05 mm dia) are to be substituted for 76 mm common wire nails then reduce the maximum kN/m to be transferred by a factor of 0.71.
  - 3) These tables are based on trusses fabricated using dry untreated lumber used in dry service conditions only.



**Figure C.1.4 – Nailing Pattern for 4-Ply Girder**

*Supplementary Notes:*

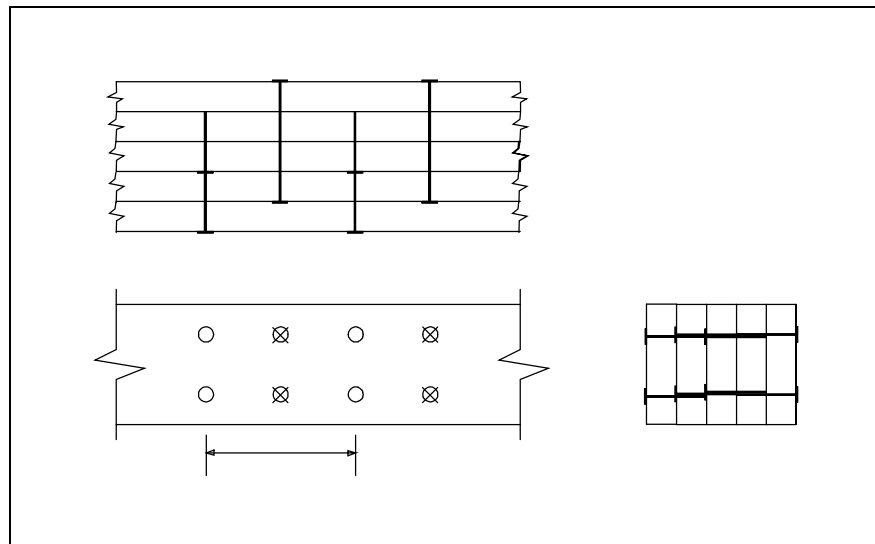
*In addition to nailing, all chords of 4 and 5 ply girders must be bolted together with ½” diameter ASTM A307 Grade A bolts and washers, 1 bolt per panel (see Clause 6.7.4.2(3)).*

**Table C.1.5**  
**Maximum Factored Load Applied to Outer Lamination of**  
**5 Ply Girder Truss with 76 mm Nails and S-P-F Lumber kN/m**

NUMBER OF ROWS	SURFACE NAIL SPACING, mm		
	305	152	127*
1	2.90	5.80	6.96
2	5.80	11.60	13.92
3	8.70	17.40	20.88
4	11.60	23.20	27.84
5	14.50	29.00	34.81
6	17.40	34.81	41.77

\* Inner ply rows should be offset for spacing

- NOTE:
- 1) Load duration factor for “Standard Term” loading has been used in the computation of data in the table.
  - 2) If 76 mm power driven nails (3.05 mm dia) are to be substituted for 76 mm common wire nails then reduce the maximum kN/m to be transferred by a factor of 0.71.
  - 3) These tables are based on trusses fabricated using dry untreated lumber used in dry service conditions only.



**Figure C.1.5 – Nailing Pattern for 5-Ply Girder**

*Supplementary Notes:*

*In addition to nailing, all chords of 4 and 5 ply girders must be bolted together with ½” diameter ASTM A307 Grade A bolts and washers, 1 bolt per panel (see Clause 6.7.4.2(3)).*

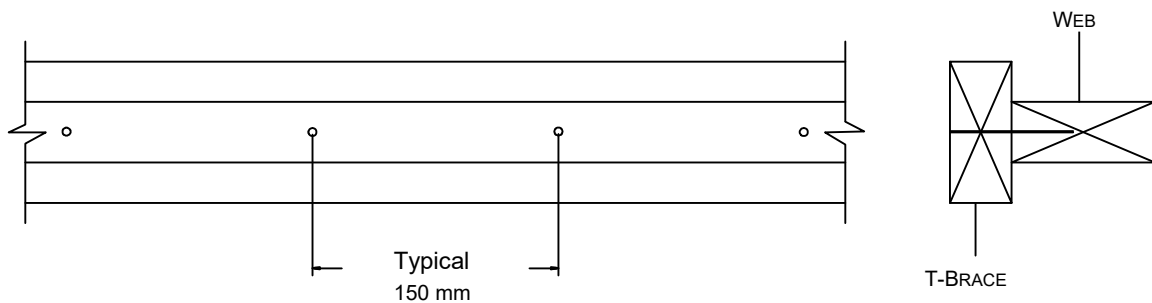
## Appendix D Individual web reinforcement

**Table D.1**  
**Maximum Web Force in Compression, kN**  
**With One 38 x 89 T-Brace**

Web Length mm	T-BRACE Web	38 x 89			
		38 x 64	38 x 89	38 x 114	38 x 140
915		27.75	37.99	47.83	57.31
1220		23.61	31.61	39.00	45.89
1525		18.95	24.75	29.90	34.55
1830		14.63	18.70	22.18	25.24
2135		11.11	13.94	16.30	18.34
2440		8.41	10.41	12.05	13.45
2745		6.41	7.86	9.03	10.02
3050		4.94	6.02	6.88	7.59

*Supplementary Notes:*

- *Web and T-brace material to be S-P-F No. 2 or better.*
- *Load duration factor for Standard Term loading has been included in the computation of data in the table.*
- *Load sharing has been included.*



Nailing – 76 mm Common Wire Nails @ 150mm O.C

**Figure D.1**  
**Nailing Pattern for T-Bracing on Single Ply Web**

## Appendix E

### Top chord bearing guidelines

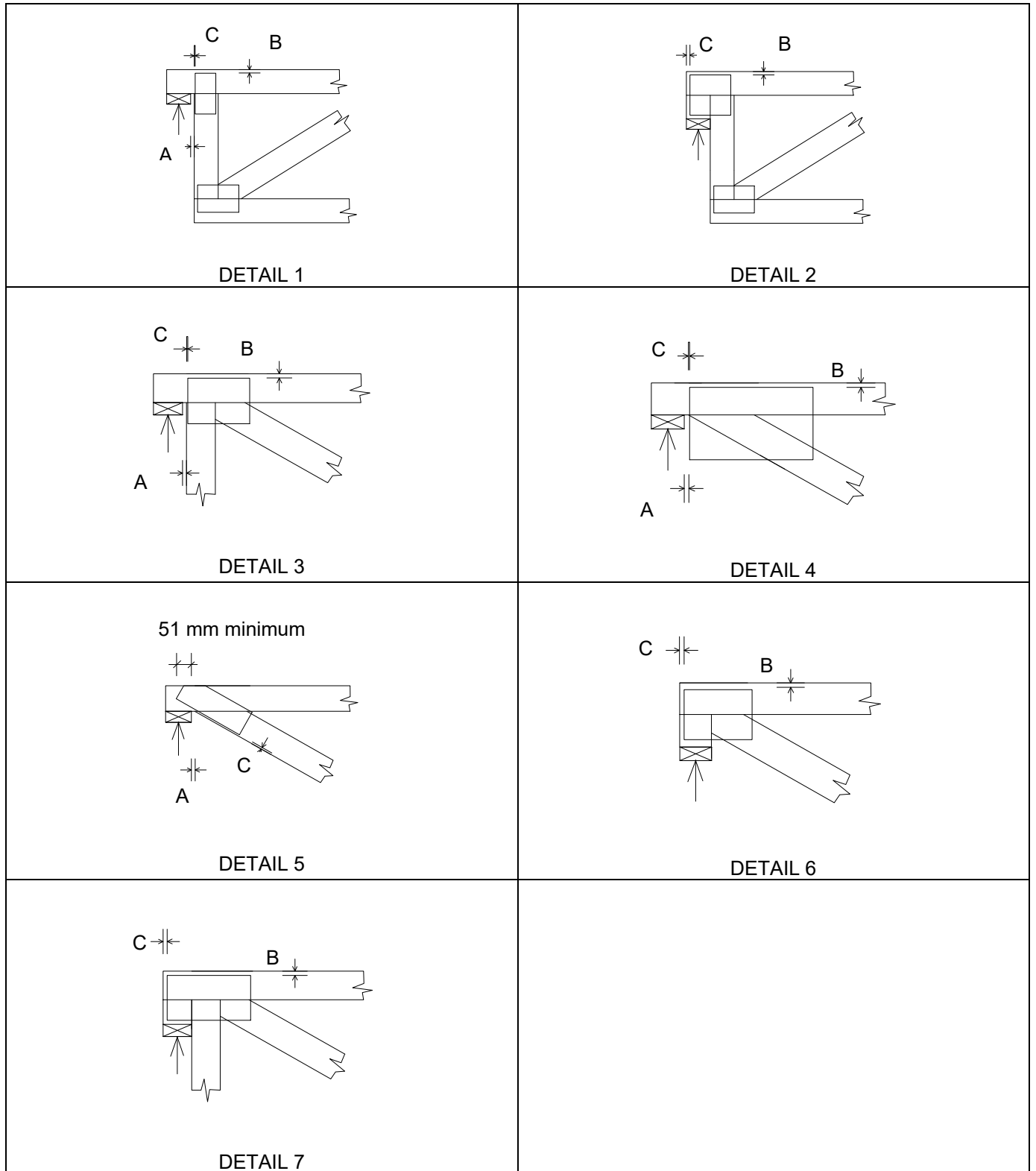
**Table E.1**  
**Top Chord Bearing Joint Guidelines for Lumber on Edge**

Bearing Detail Detail See Figure E.1	Top Chord Size mm	Diagonal Size Min mm	Maximum Factored Reaction kN	Max Allowable Gap mm		
				A	B	C
Detail 1	38 x 89	N/A	14.10	13	13	3.2
Detail 2	38 x 89	N/A	14.10	N/A	13	13
Detail 3,4	38 x 89	38 x 89	11.98	13	13	3.2
	38 x 114	38 x 89	14.80	13	38	3.2
	38 x 140*	38 x 89	17.62	13	51	3.2
Detail 5	38 x 89	38 x 89	16.92	13	N/A	6.4
	38 x 114	38 x 89	19.03	13	N/A	6.4
	38 x 140*	38 x 89	21.15	13	N/A	6.4
Detail 6,7	38 x 89	38 x 89	16.92	N/A	13	13
		38 x 114	19.74	N/A	13	13
		38 x 140	22.56	N/A	13	13
	38 x 114	38 x 89	17.27	N/A	38	13
		38 x 114	21.32	N/A	38	13
		38 x 140	25.38	N/A	38	13
	38 x 140*	38 x 89	17.62	N/A	50	13
		38 x 114	22.91	N/A	50	13
		38 x 140	28.20	N/A	50	13

\* Or Greater

- (1) The maximum factored reactions shown are for S-P-F, D.Fir-L, or SCL chords with strength properties greater than or equal to S-P-F No.1/No.2.
- (2) The values shown are only applicable to angles between the truss and the wall of 90°.

**Figure E.1**  
**Typical Top Chord Bearing Joint Guidelines for Lumber on Edge**

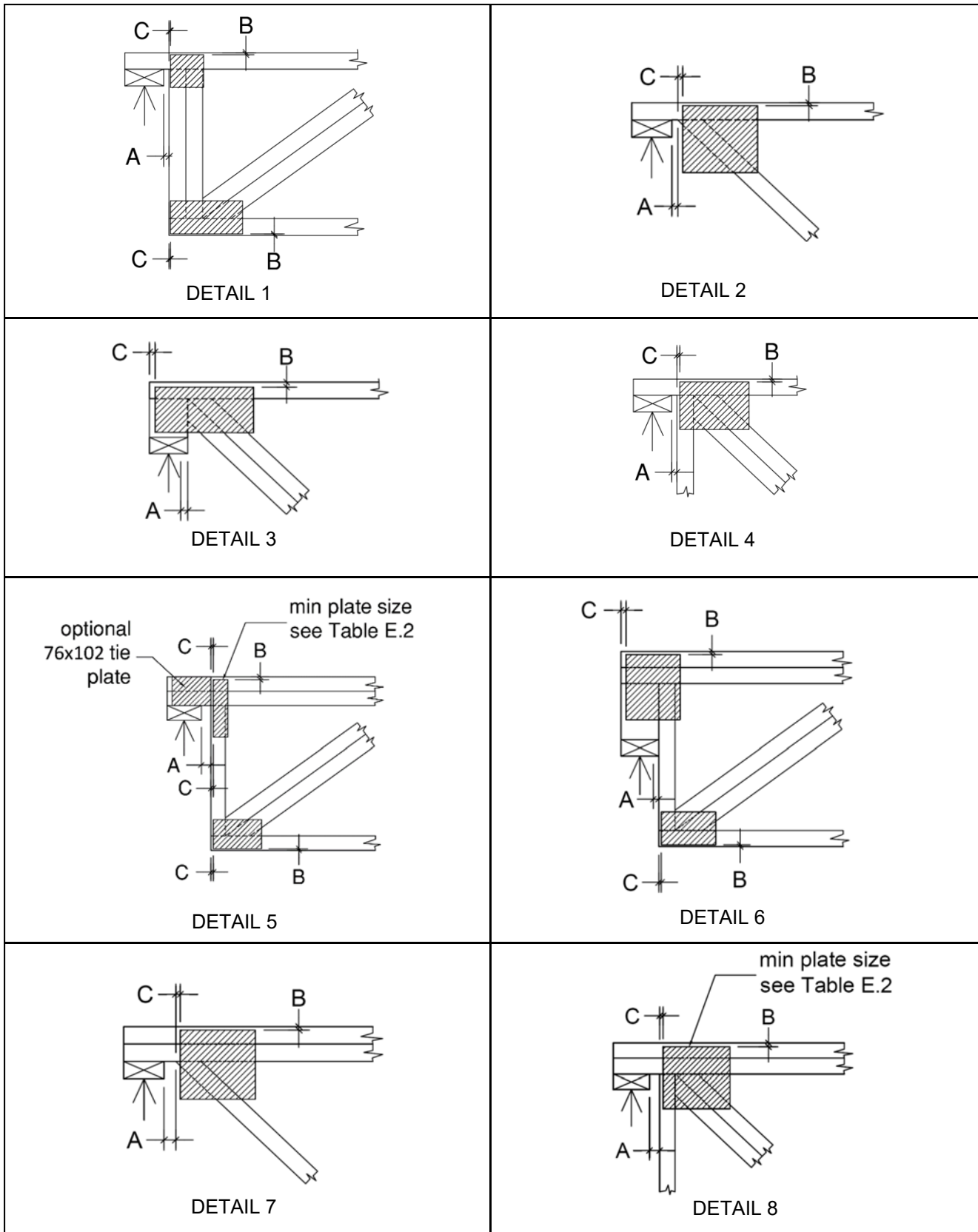


**Table E.2**  
**Top Chord Bearing Joint Guidelines for Lumber on Flat**

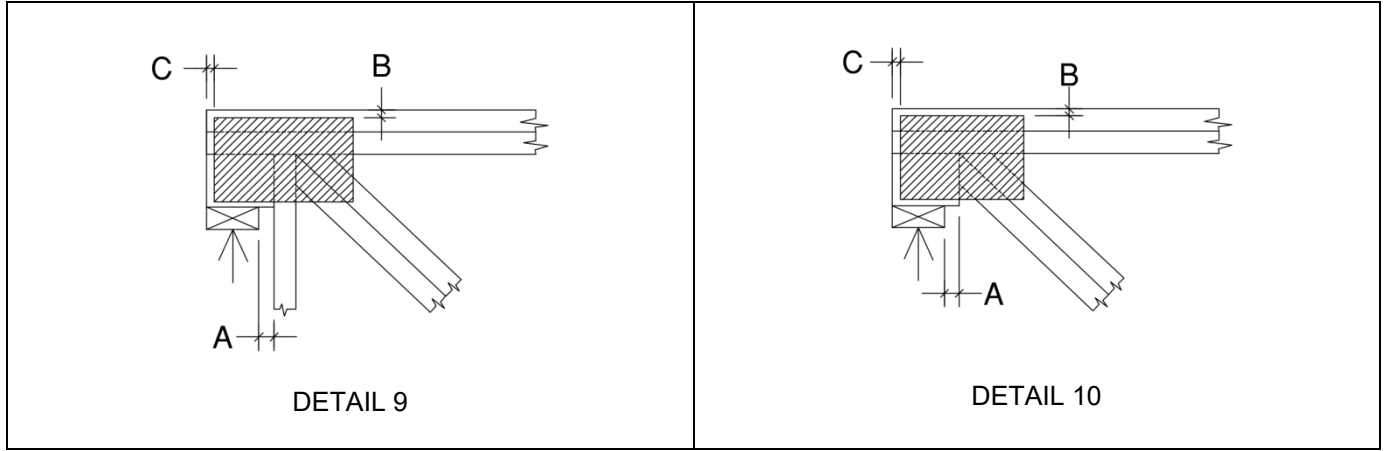
Top Chord Bearing Type as Shown in Figure E.2		Angle <sup>4</sup> to wall (degrees)	Maximum <sup>7</sup> Factored Reaction	Maximum Allowable Gap mm (in)			Min <sup>1</sup> Plate Size  (mm x mm)
				A <sup>6</sup>	B	C	
Single Top Chord 4x2	Detail 1, 2	90	4.23	13	3.2	3.2	-
	Detail 3	90	11.28	13	3.2	13	-
	Detail 4	90	4.23	13	3.2	3.2	-
Double Top Chord 4x2	Detail 5	90	11.28	13	3.2	3.2	-
			7.12	64	3.2	3.2	102x203
	Detail 5 w/ tie-plate <sup>3</sup>	45 to 90	5.33	64	3.2	3.2	102x203
	Detail 6	90	11.28	13	3.2	13	-
	Detail 7	90	11.28	13	3.2	3.2	-
	Detail 8	45 to 90	11.28	13	3.2	3.2	-
			6.59	89	3.2	3.2	152x178
	Detail 9	45 to 90	16.6	13	3.2	13	-
			11.78	89	3.2	13	-
	Detail 10	45 to 90	18.71	13	3.2	13	-
12.05			89	3.2	13	-	
Double Top Chord 3x2	Detail 7	90	8.06	13	3.2	3.2	-
	Detail 8	90	8.06	13	3.2	3.2	-

- (1) The minimum plate sizes shown are specific to the detail and the allowable gap. Where no minimum plate size is given, the plate shall be designed based on the requirements elsewhere in this standard.
- (2) The maximum factored reactions shown are for S-P-F or D.Fir-L chords.
- (3) Where tie-plates are specified they shall be a minimum 75 mm x 100 mm. See Figure E.2 for individual details.
- (4) See Figure E.3 for angle to wall applications.
- (5) The maximum factored reactions shown are based on the specific number of web and chord members shown in the details in Figure E.2.
- (6) The gap "A" is measured along the centreline of the truss.
- (7) The maximum factored reactions for details 8, 9 or 10 with gap "A" less than 89 mm may be computed using linear interpolation between the tabulated values at 13 mm and 89 mm.
- (8) The values shown in Table E.2 are applicable to standard term load duration ( $K_D=1.00$ ) with no further increase permitted. Reduce the values per 6.4.4.2.2 for long term loads.

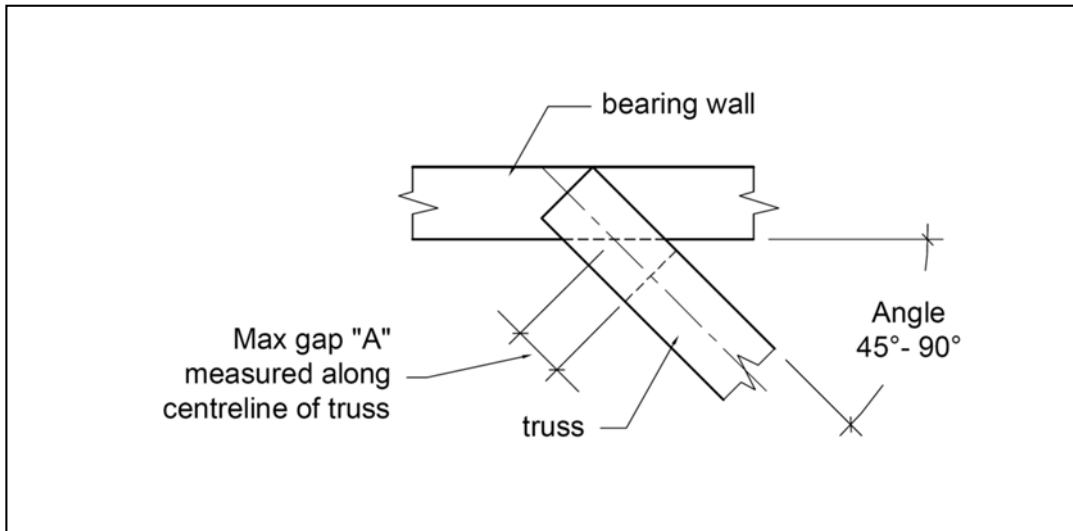
**Figure E.2**  
**Typical Top Chord Bearing Joint Guidelines for Lumber on Flat**



**Figure E.2**  
**Typical Top Chord Bearing Joint Guidelines for Lumber on Flat**



**Figure E.3**  
**Top Chord Bearing Joint Guidelines for Lumber on Flat Bearing on Angled Wall**





## Appendix F

### Shear plate design for girder-type heel joint

#### F.1 Scope

The shear plate reinforcing procedures outlined in Appendix F are applicable to sawn lumber truss chords and do not apply to chords made of structural composite lumber. For girder-type heel cuts in structural composite lumber chords, special consideration must be given to the design procedures provided by the manufacturer for this joint geometry.

In lieu of a design procedure provided by the structural composite lumber manufacturer, the APA document “*APA G535: Field Notching and Drilling of Laminated Veneer Lumber, June 2010 rev.*” may be used as an alternate procedure for estimating the stresses in a structural composite lumber truss chord with a girder-type heel cut.

#### F.3 Definitions

Truss Point - the intersection of the centreline of top chord and the centreline of bottom chord.

Projection Point - the intersection of the 45° line from the inside edge of the bearing and the centreline of the bottom chord.

Top Chord Point - the beginning point of the top chord scarf.

#### F.4 Shear plate requirements

A shear check is required when the projection point is closer to the end of the truss than the truss point. Shear plates are required if:

$$V_f > V_{rW}$$

where

$V_f$  = the factored shear force at the girder heel = the factored reaction, N

$V_{rW}$  = factored shear resistance of the lumber without plates, N

$$= \phi F_v \frac{2}{3} t n D' K_{zV} K_F$$

where

$$\phi = 0.9$$

$$F_v = f_v K_D K_{HV} K_{SV} K_T$$

$t$  = lumber thickness per ply, mm

$f_v$  = specified strength in shear, MPa (Tables 6.4 and 6.5 of CSA O86-19)

$n$  = number of plies

$K_D$  = load duration factor (Clause 6.4.4.2)

$K_{HV}$  = system factor for shear (Clause 6.4.4.5)

$K_{SV}$  = service condition factor for shear (Clause 6.4.4.6)

$K_T$  = treatment factor (Clause 6.4.4.4)

$D'$  = lumber depth at projection point, mm (Figure F.1)

$K_{zV}$  = size factor for shear (Clause 6.4.4.6)

$K_F$  = flat roof factor (Clause 6.4.4.7)

#### F.5 Shear plate design

The shear plate shall be sized and placed about the centreline of bottom chord to cover the distance  $L'$  such that:

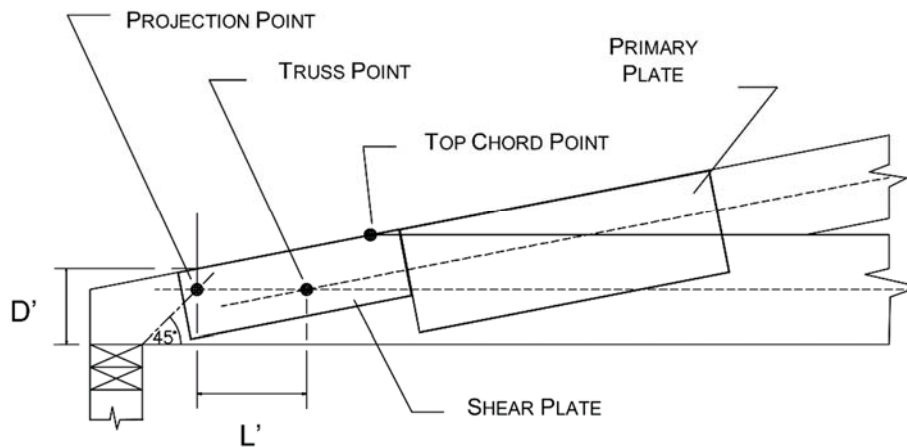
- (1) The area of the shear plate above or below the centreline of bottom chord shall be capable of resisting the net factored shear force at the girder heel, as follows:

$$V_{fNet} = \frac{1.5L'(V_f - V_{rW})}{D'n}$$

where

$L'$  = distance between projection point and truss point, mm (Figure F.1)

- (2) The length of the shear plate along the centreline of bottom chord shall be such that the shear capacity of the plate, along the centreline of bottom chord, is greater than or equal to the net factored shear force at the girder heel. The shear length as calculated shall not be less than  $L'$ .
- (3) Where the primary plate interferes with the placement of the secondary shear plate then the primary plate shall be specified long enough to provide the required grip and metal shear capacity due to the net shear force.
- (4) The tapered depth of the bottom chord at the inside edge of bearing shall not be less than half the bottom chord size or 100 mm whichever is greater.
- (5) An additional moment check shall be carried out due to extension of the bottom chord past the top chord. The moment to be used for this check is the overall span reaction times the distance from the inside edge of the bearing to the top chord point.



**Figure F.1**  
**Shear Plate Design for Girder Heel Joint**

## **Appendix G**

### **Manufacturing and Material Variances**

#### **G.1 Scope**

The purpose of this appendix is to establish minimum allowances to be used with the TPIC 2019 design procedures to account for material defects and variances in workmanship. It is the responsibility of the manufacturer to adjust these allowances for trusses that cannot be manufactured within the limits described in this appendix.

#### **G.2 Truss shop drawing**

The truss shop drawings are the drawings provided to the plant personnel for the fabrication of each truss. They include enlarged joint details, tooth count requirements, cutting list, truss layout and/or jig location details.

#### **G.3 Materials**

##### **G.3.1 Lumber**

###### **G.3.1.1 General**

The lumber shall meet the criteria as described in Clause 4.1 and be the size, species and grade (or better) specified on the Truss Shop Drawings.

###### **G.3.1.2 Splits in wood members**

Splits in any wood member caused by the manufacturing process shall not exceed those permitted in the grade and species of lumber used.

##### **G.3.2 Metal connector plates**

###### **G.3.2.1 General**

Metal connector plates shall meet the criteria as described in Clause 4.2 and be of the gauge, type, manufacturer, width and length as specified on the Truss Shop Drawing.

#### **G.4 Plating**

Clause 7 describes the conditions for which the design criterion for truss plates is based. To allow for minimum manufacturing and material variances the plate design criteria shall be adjusted to allow for plate misplacement and ineffective teeth. This section provides the procedure to adjust the design criteria to match that which is generally achievable in the manufacturing process.

##### **G.4.1 Tooth effectiveness**

###### **G.4.1.1 Effective teeth**

Effective teeth are teeth fully embedded normal to the surface of the lumber and into quality wood of the member.

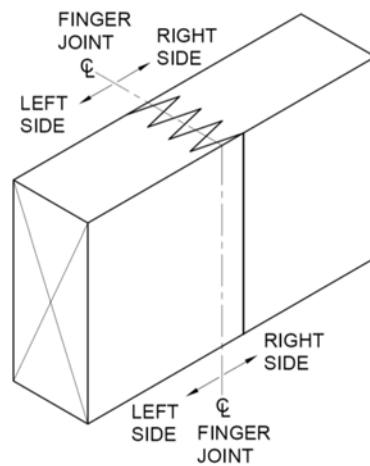
## G.4.1.2 Ineffective teeth

### G.4.1.2.1 General

Ineffective teeth are teeth that are improperly embedded and cannot resist loading. Examples include teeth located over wane, knot holes, loose or decayed knots, pitch pockets, unsound wood, fingerjoints, holes and joint gaps or teeth that have been flattened before or during the pressing, or that have a tooth embedment gap of 1.6 mm (1/16") or greater. Except for heel joints, teeth located within the 12.7 mm (1/2") end and 6.4 mm (1/4") edge distances of the lumber are considered to be ineffective when the design is based upon the net area method.

### G.4.1.2.2 Fingerjoints

Ineffective teeth in a fingerjoint are teeth that contain wane, knot holes, loose or decayed knots, pitch pockets, unsound wood or holes on one side or both sides of the fingerjoint. Teeth in a fingerjoint that the lumber on one side of the joint has discoloration due to burning that occurs when the board stops in the cutter head are considered ineffective on the side of the joint that this discoloration occurs.



**Figure G.4.1.2.2**  
**Fingerjoint geometry**

### G.4.1.3 Partially effective teeth

Teeth not completely embedded and can resist loading may be considered to be partially effective. When a metal connector plate is installed in the connection area of lumber which contains tooth holes from a previously installed plate and where the wood is otherwise undamaged, metal connector plate teeth shall be considered 50% effective.

### G.4.1.4 Minimum effective teeth

#### G.4.1.4.1 Lumber on edge (wide face plating)

The truss designer shall provide a minimum 10% reserve capacity in grip for each member to allow for ineffective teeth. This requirement may be met by limiting the grip JSI to 0.90 in each member. The required number of effective teeth in each member shown on truss shop drawings or in lists shall be calculated according to Clause 7. This means that in the manufacturing process, the average number of effective teeth for both sides of the joint in any member shall never be less than the required number of teeth specified on the shop drawing. When averaging the effective teeth on both sides no one side shall have less than 85% of the specified effective teeth required.

#### G.4.1.4.2 Lumber on flat (narrow face plating)

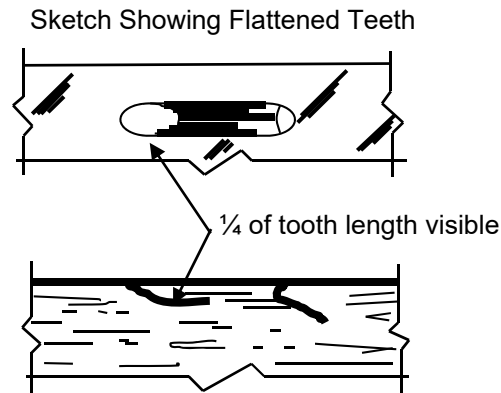
The truss designer shall provide a minimum 5% reserve capacity in grip for each member to allow for ineffective teeth. This requirement may be met by limiting the grip JSI to 0.95 in each member. The required number of effective teeth in each member shown on truss shop drawings or in lists shall be calculated according to Clause 7. This means that in the manufacturing process, the average number of effective teeth for both sides of the joint in any member shall never be less than the required number of teeth specified on the shop drawing. When averaging the effective teeth on both sides no one side shall have less than 85% of the specified effective teeth required.

#### G.4.1.4.3 Joint Stress Index

The Joint Stress Index (JSI) is the ratio of the calculated force in a member to the lateral resistance of the teeth in that member. Example: If a member has a design force of 4.0 kN in it and the teeth of the connector plate has a lateral resistance of 4.45 kN, the JSI = 0.90.

#### G.4.1.5 Tooth flattening

After pressing, teeth are considered flattened and ineffective if  $\frac{1}{4}$  or greater of the tooth is visible within the tooth slot. A tooth shall also be considered flattened if the surface of the wood has raised (i.e., wood lifted up beyond its normal surface plane) within the tooth-slot opening of the metal connector plate.

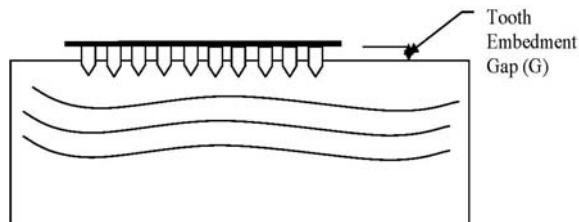


Both teeth are considered ineffective within a tooth slot.

**Figure G.4.1.4.3**  
**Flattened teeth**

#### G.4.1.6 Tooth embedment gap

After pressing, all teeth of each connector plate shall be completely embedded in each wood member. Teeth with an embedment gap of less than 0.8 mm ( $\frac{1}{32}$ " ) shall be considered effective. Teeth with a gap equal to or greater than 1.6 mm ( $\frac{1}{16}$ " ) shall be considered ineffective. Teeth with a gap between 0.8 mm ( $\frac{1}{32}$ " ) and 1.6 mm ( $\frac{1}{16}$ " ) shall be considered to be 60% effective.



**Figure G.4.1.6**  
**Tooth embedment gap**

**Table G.4.1.6**  
**Tooth effectiveness – embedment gap**

Tooth Embedment Gap (G)	Tooth Effectiveness
0 mm < G < 0.8 mm (0" < G < 1/32")	100%
0.8 mm ≤ G < 1.6 mm (1/32" ≤ G < 1/16")	60%
G ≥ 1.6 mm (G ≥ 1/16")	0%

## G.4.2 Plate placement tolerances

### G.4.2.1 General

#### G.4.2.1.1 Lumber on edge

During the truss manufacturing process, plates shall be positioned according to the Truss Shop Drawing and should be placed within the 6.4 mm (1/4") plate placement translation tolerance and within the plus and minus five degree ( $\pm 5^\circ$ ) plate rotation tolerance. In no case shall the positioning decrease the number of effective teeth in any member to less than the minimum number required for that member.

#### G.4.2.1.2 Lumber on flat

During the truss manufacturing process, plates shall be positioned according to the Truss Shop Drawing and should be placed within the 3.2 mm (1/8") plate placement translation tolerance. In no case shall the positioning decrease the number of effective teeth in any member to less than the minimum number required for that member. Due to relative ease of locating plates parallel to and near the edge of lumber, no allowance for rotational misplacement is required.

#### G.4.2.1.3 Misplacement limits

In both the translational and rotational checks these misplacements are limited to the outer boundaries of the truss. Translation and Rotation checks are done independent of each other.

### G.4.2.2 Translation

#### G.4.2.2.1 Lumber on edge

The truss designer shall use a minimum plate placement translation tolerance of 6.4 mm (1/4") parallel and perpendicular to the plate axis. The designer shall select a plate size and placement for each joint that resists the lateral forces in each member. The plate shall then be shifted by 6.4 mm (1/4") up, down, left, right, up and to the left, up and to the right, down and to the left, and down and to the right, and shall be checked to verify that a JSI of 0.90 is not exceeded in any member.

#### G.4.2.2.2 Lumber on flat

The truss designer shall use a minimum plate placement translation tolerance of 3.2 mm (1/8") parallel and perpendicular to the plate axis. The designer shall select a plate size and placement for each joint that resists the lateral forces in each member. The plate shall then be shifted by 3.2 mm (1/8") up, down, left, right, up and to the left, up and to the right, down and to the left, and down and to the right, and shall be checked to verify that a JSI of 0.95 is not exceeded in any member.

## G.4.2.3 Rotation

### G.4.2.3.1 Lumber on edge

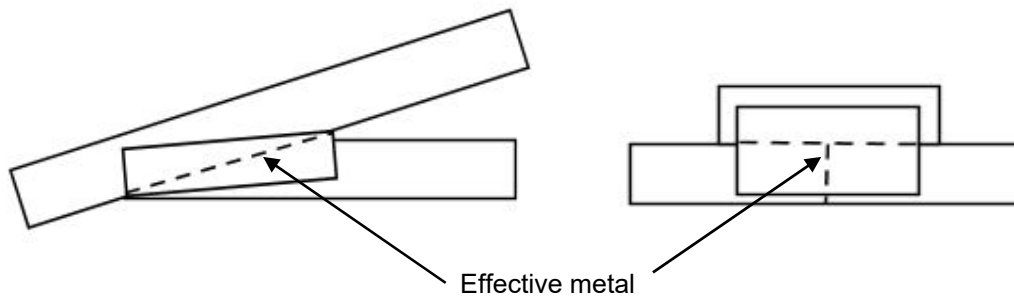
The truss designer shall also use a minimum plate placement rotation tolerance of plus and minus five degrees ( $5^\circ$ ) about the centre of the connector plate. The designer shall select a plate size and placement for each joint that resists the lateral forces in each member. The plate shall then be rotated  $5^\circ$  clockwise and checked to verify that a JSI of 0.90 is not exceeded in any member. The plate shall then be rotated  $5^\circ$  counterclockwise from its original position and checked to verify that a JSI of 0.90 is not exceeded in any member. If the plate does not resist the force in any member, the plate size is increased and checked again for the two rotated ( $+5^\circ$  and  $-5^\circ$ ) positions.

### G.4.2.3.2 Lumber on flat

Due to relative ease of locating plates parallel to and near the edge of lumber, no allowance for rotational misplacement is required.

### G.4.2.3 Metal effectiveness

- (1) The truss designer shall ensure the sum of the length or width of metal across each side of a joint shall adequately resist the shear or tension forces at the joint. This check also applies to each shifted location and rotated location using the appropriate shear and breaking values for these locations and actual length or width of metal across the joint.
- (2) All supplemental blocking such as wedges and splice blocks must be installed as per the Truss Shop Drawing.

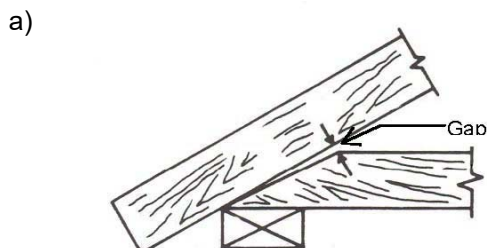


**Figure G.4.2.3**  
**Metal effectiveness**

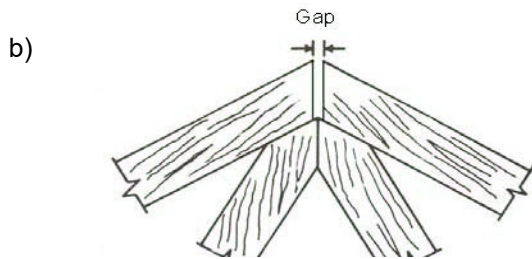
## G.5 Truss assembly

### G.5.1 Member to member gaps

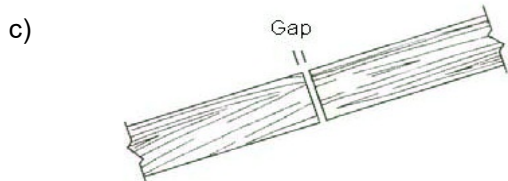
Members at each joint should have wood to wood bearing at each interface. Gaps in joints after pressing shall not exceed 1.6 mm ( $1/16$  inch) for compression splices including pitch breaks and 3.2 mm ( $1/8$  inch) for all other joints.



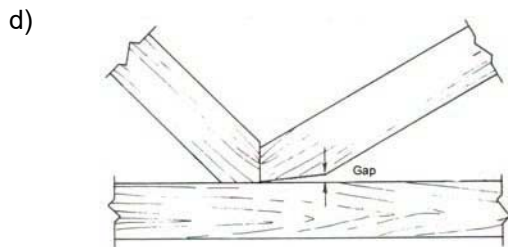
Gap between Top and Bottom Chords in heel joints shall not exceed 3.2 mm ( $1/8$ " )



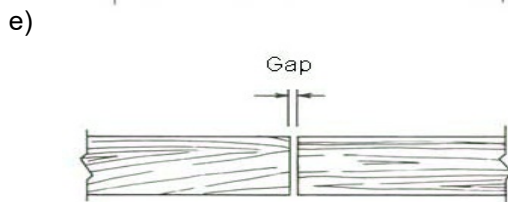
Gap between Top Chords in a Peak joint shall not exceed 1.6 mm (1/16")



Gaps in Compression Splices shall not exceed 1.6 mm (1/16")



Gaps in interior webs shall not exceed 3.2 mm (1/8")



Gaps in Tension Splices shall not exceed 3.2 mm (1/8")

**G.5.2 Overall truss dimensions**

The dimensions of a completed truss if different from those as specified on the Truss Shop Drawing shall not exceed the differences shown in the following table:

Truss Dimensions	Maximum Difference between specified and measured dimensions
Length ≤ 9144 mm (30 feet)	6.4 mm (1/4")
Length > 9144 mm (30 feet)	12.7 mm (1/2")
Overall Height ≤ 1200 mm (4 feet)	3.2 mm (1/8")
Overall Height > 1200 mm (4 feet)	6.4 mm (1/4")
Left Heel/Stub Height	3.2 mm (1/8")
Right Heel/Stub Height	3.2 mm (1/8")
Left Overhang	3.2 mm (1/8")
Right Overhang	3.2 mm (1/8")



## Appendix H

### Minimum Information on Truss Design Drawings

#### H.1 General

Truss Design Drawings shall include, but not limited to, the information specified below:

- (1) Building code, CSA and TPIC Standard to which the drawing complies to.
- (2) Slope or depth, span and spacing.
- (3) Location of all joints and support locations.
- (4) Input and required bearing widths.
- (5) Software version number.
- (6) Specified loads, as applicable, shall include:
  - a. Top chord variable loads (including snow, live loads).
  - b. Top chord dead load.
  - c. Bottom chord live load due to limited accessibility.
  - d. Bottom chord dead load.
  - e. Wind loads
  - f. Other lateral loads, including drag strut loads.
  - g. Statement of whether special loading requirements have been checked including but not limited to unbalanced loading, minimum concentrated loads, etc.
  - h. All additional loads and their points of application as applicable.
- (7) Adjustments to wood member and metal connector plate design value for conditions of use.
- (8) Adjustments made to material strength due to load sharing.
- (9) Connection requirements for truss ply to ply.
- (10) Maximum factored reaction force and direction, including maximum factored uplift reaction forces where applicable.
- (11) Maximum CSI on top chord, bottom chord and webs.
- (12) Maximum un-factored reaction force and direction for each load type.
- (13) Metal connector plate type, manufacturer, size, and thickness or gauge, and the dimensioned location of each metal connector plate except where symmetrically located relative to the joint interface.
- (14) Size, species and grade for each wood member.
- (15) Calculated maximum vertical and horizontal deflection for variable load and total load as applicable.
- (16) Maximum axial tension and compression forces in the Truss members.
- (17) Fabrication Tolerance used per Appendix G.
- (18) Required Permanent Individual Truss Member Restraint location shall be shown for lateral bracing. Fastening of the lateral brace, T/I-brace, scab brace, L-brace shall be specified.
- (19) Drawing identification.
- (20) Design equation used for combined bending and compression member design.
- (21) Output error messages when design exceeds limits.



Truss Plate Institute of Canada  
[www.tpic.ca](http://www.tpic.ca)