

DECKS AND EXTERIOR GUARDS FOR HOUSING

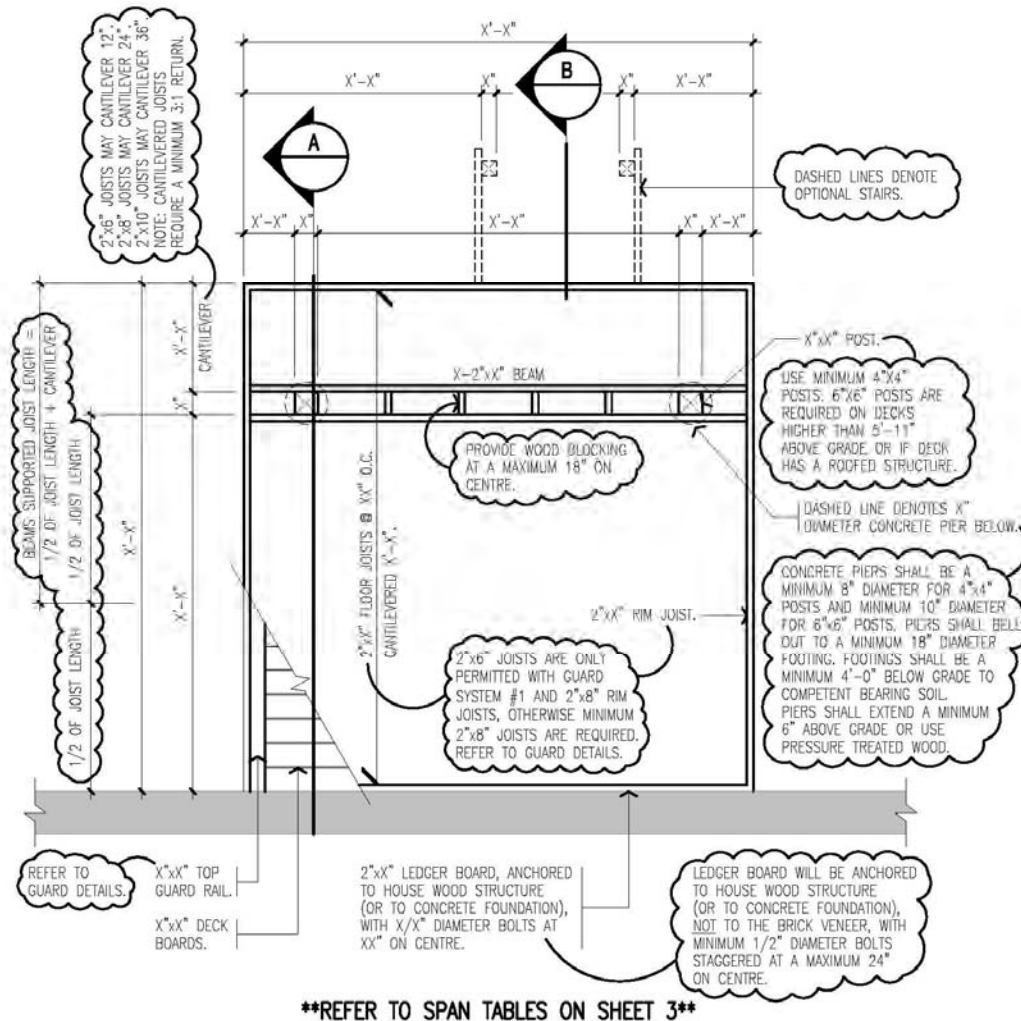

NOTES:

1. DRAWINGS ARE NOT TO BE USED FOR CONSTRUCTION
2. DRAWINGS ARE FOR SAMPLE PURPOSES ONLY
3. DO NOT SUBMIT THIS DRAWING AS PART OF YOUR DRAWING PACKAGE
4. PLANS SUBMITTED FOR REVIEW ARE TO BE DRAWN AT A RECOGNIZED SCALE. FOR EXAMPLE 1/4" = 1' OR 1/2" = 1'.
5. REFER TO THE TOWN OF ERIN ZONING BY-LAW FOR ZONING REQUIREMENTS.

LEGEND:



DENOTES MINIMUM CODES

X' - X", X",
2 x X", XX DENOTES INFORMATION THAT IS REQUIRED IN YOUR DRAWING PACKAGE, THIS INFORMATION CONSISTS OF DIMENSIONS, SIZES FOR STRUCTURAL ELEMENTS AND OTHER MATERIALS

DECKS AND EXTERIOR GUARDS FOR HOUSING

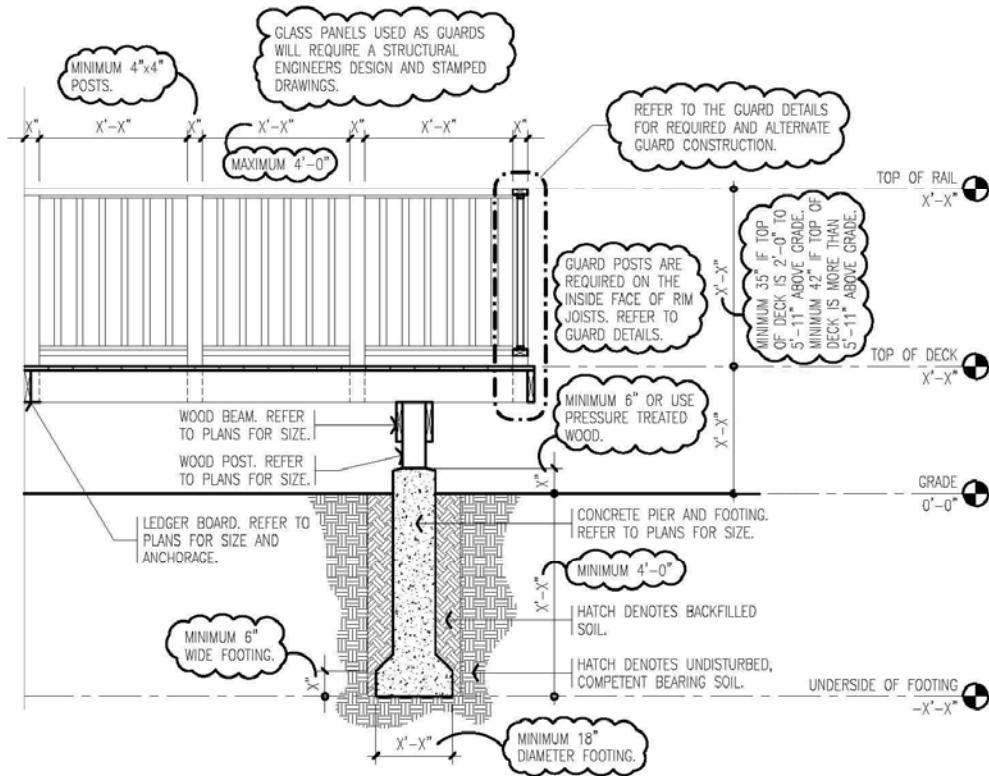

****FOR LOTS CONTAINING ENGINEERED FILL REFER TO CONNECTION DETAILS HANDOUT****

NOTES:

1. DRAWINGS ARE NOT TO BE USED FOR CONSTRUCTION
2. DRAWINGS ARE FOR SAMPLE PURPOSES ONLY
3. DO NOT SUBMIT THIS DRAWING AS PART OF YOUR DRAWING PACKAGE
4. PLANS SUBMITTED FOR REVIEW ARE TO BE DRAWN AT A RECOGNIZED SCALE. FOR EXAMPLE $\frac{1}{4}'' = 1'$ OR $\frac{1}{2}'' = 1'$.
5. REFER TO THE TOWN OF ERIN ZONING BY-LAW FOR ZONING REQUIREMENTS.

LEGEND:



DENOTES MINIMUM CODES

$X' - X''$, X'' , $2 \times X''$, XX DENOTES INFORMATION THAT IS REQUIRED IN YOUR DRAWING PACKAGE, THIS INFORMATION CONSISTS OF DIMENSIONS, SIZES FOR STRUCTURAL ELEMENTS AND OTHER MATERIALS

DECKS AND EXTERIOR GUARDS FOR HOUSING

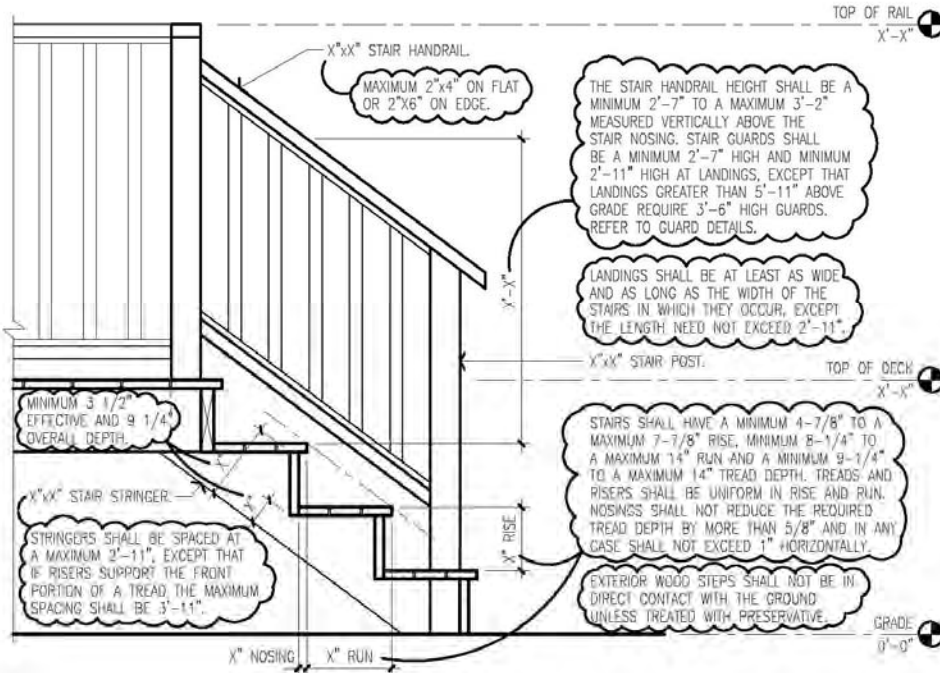

DECK JOIST	S-P-F #1 & 2	2"x6"			2"x8"			2"x10"		
		SPACING - ON CENTRE			SPACING - ON CENTRE			SPACING - ON CENTRE		
		12"	16"	24"	12"	16"	24"	12"	16"	24"
STRAPPING		9'-7"	8'-11"	8'-2"	11'-7"	11'-0"	10'-6"	13'-8"	13'-0"	12'-4"
BRIDGING		10'-4"	9'-4"	8'-2"	12'-5"	11'-9"	10'-9"	14'-6"	13'-8"	12'-10"
BRIDGING & STRAPPING		10'-4"	9'-4"	8'-2"	13'-1"	12'-2"	10'-9"	15'-1"	14'-1"	13'-2"

DECK BEAM	S-P-F #1 & 2	2"x8"			2"x10"			2"x12"		
		NUMBER OF MEMBERS			NUMBER OF MEMBERS			NUMBER OF MEMBERS		
		2-PLY	3-PLY	4-PLY	2-PLY	3-PLY	4-PLY	2-PLY	3-PLY	4-PLY
SUPPORTED JOIST LENGTH										
8'-0"		8'-7"	10'-7"	12'-2"	10'-6"	12'-11"	14'-11"	12'-2"	15'-0"	17'-4"
10'-0"		7'-8"	9'-5"	10'-11"	9'-4"	11'-7"	13'-4"	10'-10"	13'-5"	15'-6"
12'-0"		7'-0"	8'-8"	10'-0"	8'-6"	10'-7"	12'-2"	9'-11"	12'-3"	14'-2"
14'-0"		6'-6"	8'-0"	9'-3"	7'-11"	9'-9"	11'-3"	9'-2"	11'-4"	13'-1"
16'-0"		6'-1"	7'-6"	8'-8"	7'-5"	9'-2"	10'-7"	8'-7"	10'-7"	12'-3"
18'-0"		5'-9"	7'-1"	8'-2"	6'-11"	8'-7"	9'-11"	8'-1"	10'-0"	11'-7"
20'-0"		5'-5"	6'-8"	7'-9"	6'-8"	8'-2"	9'-5"	7'-8"	9'-6"	10'-11"

NOTES:

1. DRAWINGS ARE NOT TO BE USED FOR CONSTRUCTION
2. DRAWINGS ARE FOR SAMPLE PURPOSES ONLY
3. DO NOT SUBMIT THIS DRAWING AS PART OF YOUR DRAWING PACKAGE
4. PLANS SUBMITTED FOR REVIEW ARE TO BE DRAWN AT A RECOGNIZED SCALE. FOR EXAMPLE 1/4" = 1' OR 1/2" = 1'.
5. REFER TO THE TOWN OF ERIN ZONING BY-LAW FOR ZONING REQUIREMENTS.

LEGEND:



DENOTES MINIMUM CODES

X' - X", X",
2 x X", XX DENOTES INFORMATION THAT IS REQUIRED IN YOUR DRAWING PACKAGE, THIS INFORMATION CONSISTS OF DIMENSIONS, SIZES FOR STRUCTURAL ELEMENTS AND OTHER MATERIALS

DECKS AND EXTERIOR GUARDS FOR HOUSING

EXTERIOR GUARDS FOR HOUSING

SYSTEM #1

CANTILEVERED PICKET SCREWED TO RIM JOIST FROM SB-7 O.B.C.

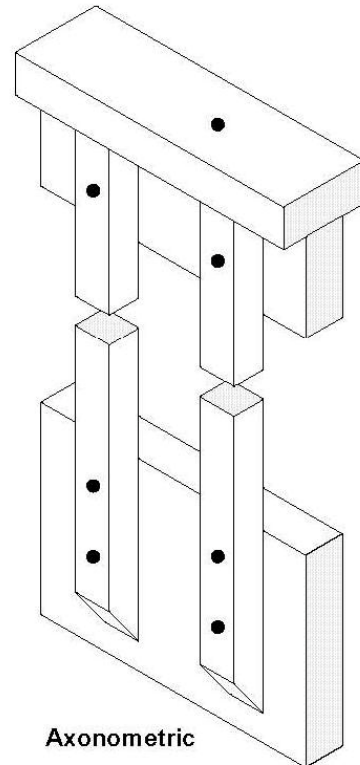
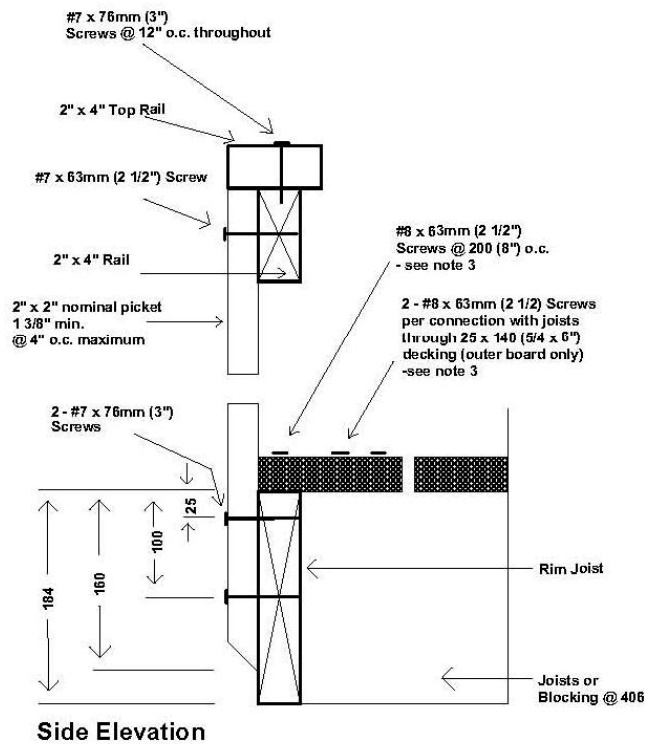

* O.C.- on centre

- 1) Provide a suitable post, return, or solid support at each end of the guard
- 2) Fasten rim joist to each floor joist with 3-82mm (3 1/4") nails
- 3) The outer deck board shall not be less than 140mm (6" nominal wide). Where 38mm (2" nominal) thick board are used, the length of the wood screws shall be not less than 76mm (3").

***Note: Consult Building Department
for any variance to design**

DECKS AND EXTERIOR GUARDS FOR HOUSING

POST CONNECTION DETAILS MAXIMUM SPACING 4' BETWEEN POSTS FROM SB-7 O.B.C.

Post Screwed to Rim Joist

Plan

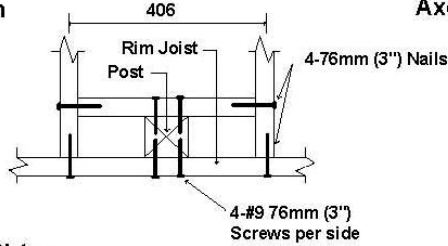

Axonometric

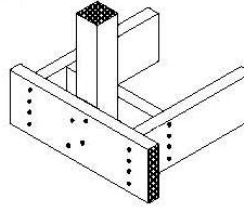

Side Elevation

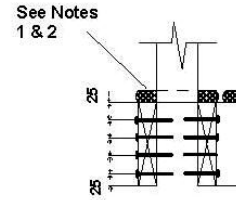

Notes:

1. Fasten 25mm x 140mm (5/4 x 6" nominal) outer deck board to rim joist with 63mm (2 1/2") nails @
2. Fasten 25mm x 140mm (5/4 x 6" nominal) outer deck board to floor joist with 1-63mm (2 1/2") nail
3. The post may be positioned anywhere between the joists.

Post Bolted to Floor Joist- 8mm (5/16") Bolts

Plan

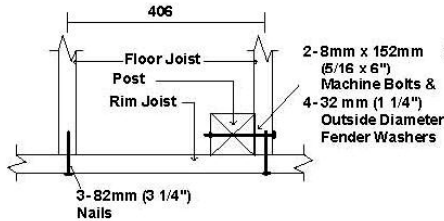

Axonometric

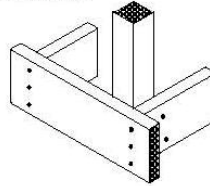

Notes:

1. Where floor joists are spaced at 610mm (24") o.c., decking shall have a minimum thickness of 38mm (1 1/2") and shall be fastened to the floor with 2 -76mm (3") nails.

Post Fastened to Floor, Guard Parallel to Floor Joists

Plan

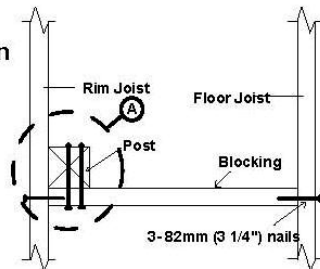

Axonometric

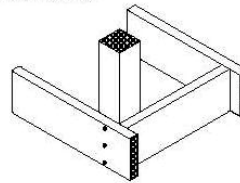

***Note: Consult Building Department for any variance to design**

Notes: Use any connection detail above at Location "A"

DECKS AND EXTERIOR GUARDS FOR HOUSING

SYSTEM #2 EXTERIOR GUARDS FOR HOUSING

TOP/BOTTOM RAIL DETAILS FROM SB-7 O.B.C.

Option #1
Top Rail Only

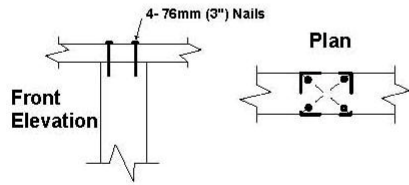

Option #2
Top or Bottom Rail

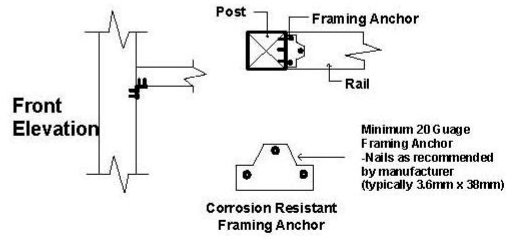

Option #3
Top or Bottom Rail

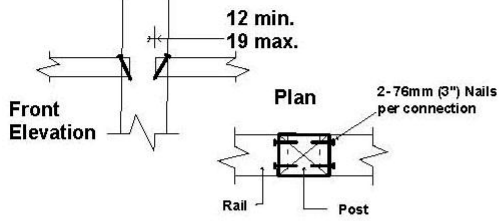

Option #4
Top or Bottom Rail

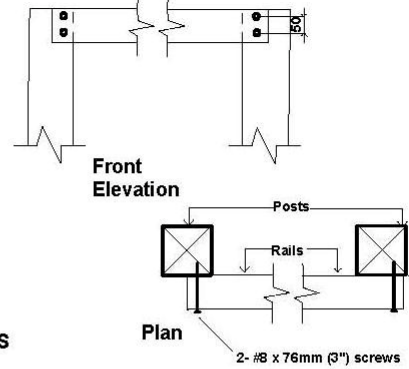

MINIMUM SIZE OF LOADBEARING ELEMENTS- ALL SYSTEMS

Guard Element	Minimum Size, mm (in.)
Post	89 x 89 (4" x 4" nominal)
Top Rail	39 x 89 (2" x 4" nominal)
Bottom Rail	39 x 89 (2" x 4" nominal)
Picket/ Baluster	32 x 32 (1 9/32" x 1 9/32" nominal)

*Picket Infill Between Posts
- min. 1 3/8" x 1 3/8" @ 4" o.c. max.
screwed at Top & Bottom

*Note: Consult Building Department
for any variance to design

DECKS AND EXTERIOR GUARDS FOR HOUSING

BEAM AND POST CONNECTIONS

TO ALLOW FOR FUTURE RAISING OF DECK IN
CASE OF SETTLEMENT

